

Каталог газорегуляторных пунктов

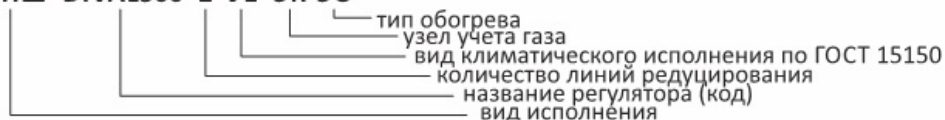

(,)

ГРПШ-DIVAL500-2-У1-ЭК-ЭО



/	/	з
-08	-32	1,2	1,2-3	300
-400 (-04)	-400	0,6	2-5	300
-400-01 (-05)	-400	0,6	2-5	600
-07	-1000	0,6	2-5	900
-01	-	1,2	2-5	1000
-03	-50 (1/2/3)	1,2	10-100	900
-03	-50	1,2	270-300	1200
-12	-1-50/35	1,2	1-60	6500
-12	-1 -50/35	1,2	30-600	6500
-13	-50	1,2	1,5-60	7100
-13	-50	1,2	60-600	7100
-14	-1-100	1,2	1-60	19000
-14	-1 -100	1,2	30-600	19000
-15	-80	1,2	1,5-60	13000
-15	-80	1,2	60-600	13000
-16	-150	1,2	1,5-60	29000
-16	-150	1,2	60-600	29000
- 100/	100/	0,05-1,2	20-450	240
-Dival500	Dival500	0,05-2,0	1,5-250	500
-Dival600	Dival600	0,05-2,0	1,2-420	2250
-Dival700	Dival700	0,05-2,0	0,5-145	450
-FEXS	FEXS	0,05-1,6	1,3-18	100
-FRG/2	FRG/2	0,05-0,6	2-40	100
-RG/2	RG/2	0,05-0,6	1-80	5000
Dixi	Dixi	0,05-1,2	0,7-400	6000
Reval	Reval182	0,05-1,6	0,7-1200	230000
Aperval	Aperval	0,05-1,9	0,5-950	60000
Norval	Norval	0,05-1,6	0,8 440	30128



- -1 1
 6 25
 0,86
 (-)
 -40...+60
 (1,3-18)
 ±5
 2,5-30
 1,0-13,0

 (1,1-1,3)
 15

- 6 - 25 - 5
 370
 300
 240
 6 10 25 50

ГРПШ-DIVAL500-2У1-ОГ(ЭО)*



^_

	-01	1.500-2	1-
01	1.500	01	1.500
	1,0		2,0
		-40...+60	
1,3	10,0	10,0	30,0
		±5	
	3...18	1,8...45	55...400
	0,6...6	10...50	10...200
/	65	/	65
	1,5-15	15-50	50-7000
		15	
		01	1500

DIVAL-500 1 1

	15-100			5	100-300		TR 300-1000			TR 1000-3000		
	5	10	20		5	10	20	5	10	520	5	10
0,5 +°	50	75	100	100	140	150	50	80	100	100	160	200
1,0 +	75	140	150	140	200	230	75	130	150	150	270	300
1,5 +2	120	200	240	200	300	300	120	200	250	300	480	500
5,0 +	140	250	300	350	350	350	130	350	350	350	350	350

	15-100			5	100-300		300-1000			1000-3000		
	5	10	20		5	10	20	5	10	520	5	10
0,5 +,	70	110	115	100	160	180	60	90	110	110	160	200
1,0 +	160	170	180	160	240	280	75	140	160	180	350	400
2,5 +	300	350	350	350	500	500	160	250	280	320	500	500
5,0 +	200	250	300	300	500	500	350	450	500	350	500	500

*

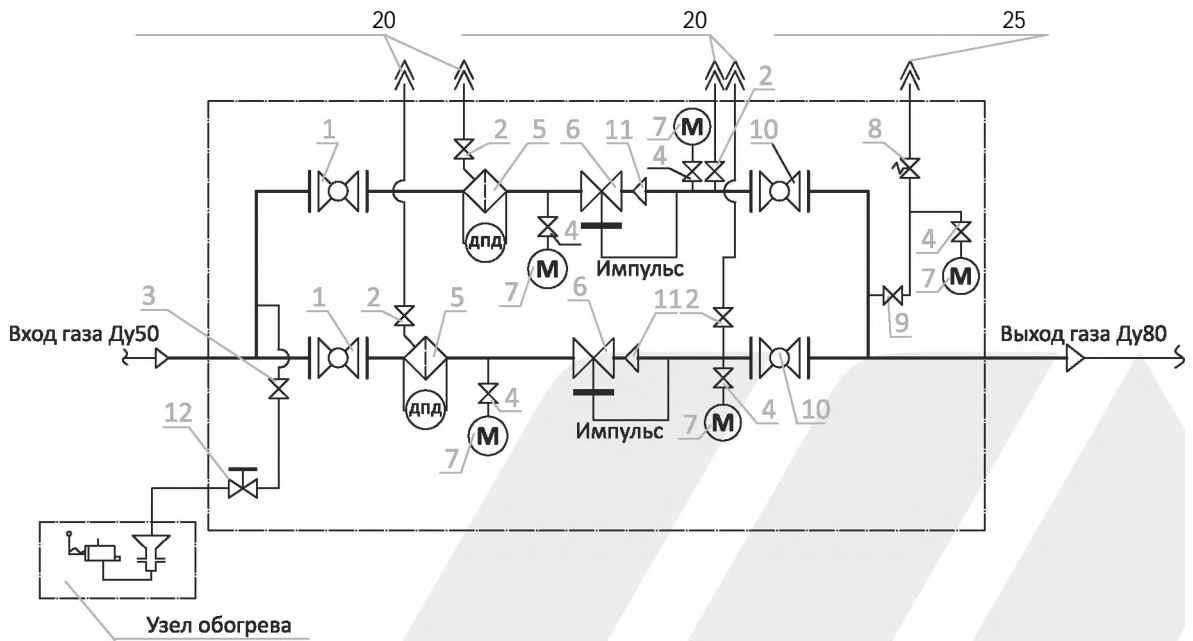

1- ; 5- ; 20; 3- / 1500 ; 7- ; 8- ; 15; 4- ; 15 / ; 9-
 50; 2- ; 25; 10- ; 80; 11- ; 50- 80; 12- ; 6

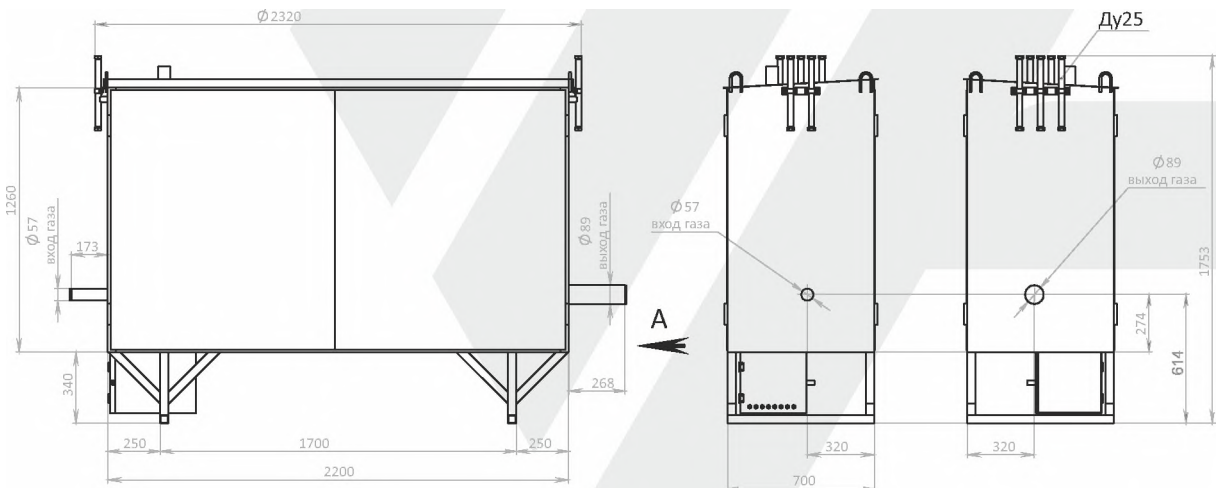

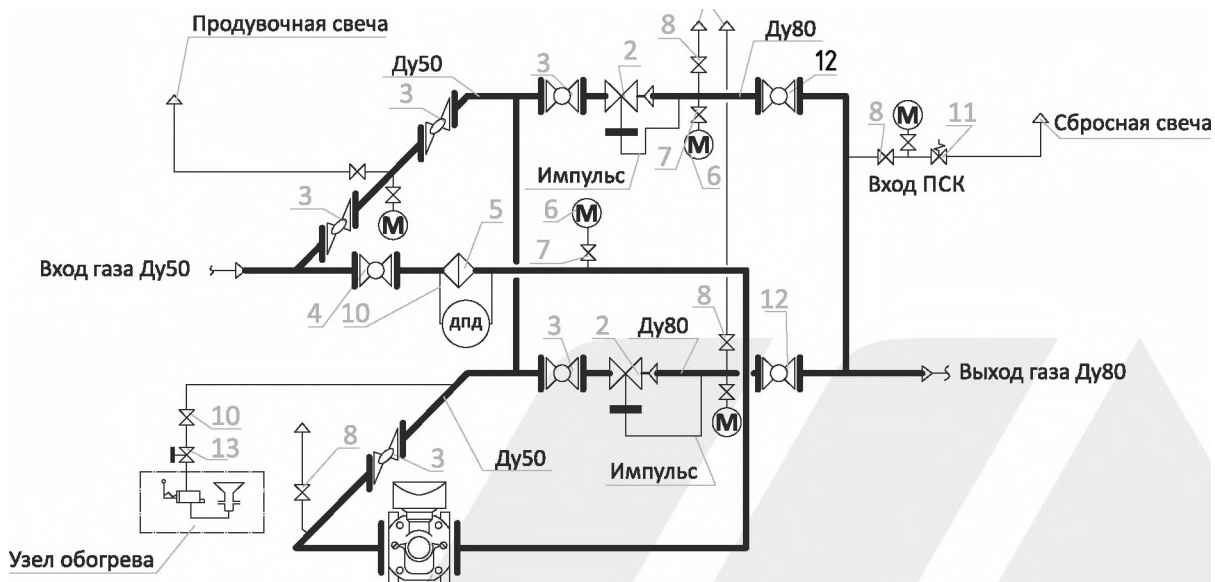

1- ; 2- 1500; 3- 50; 4- 50 ;
 5- / ; 11- ; 7- 80; 12- 15; 8- -1,1,2 25; 10- 50

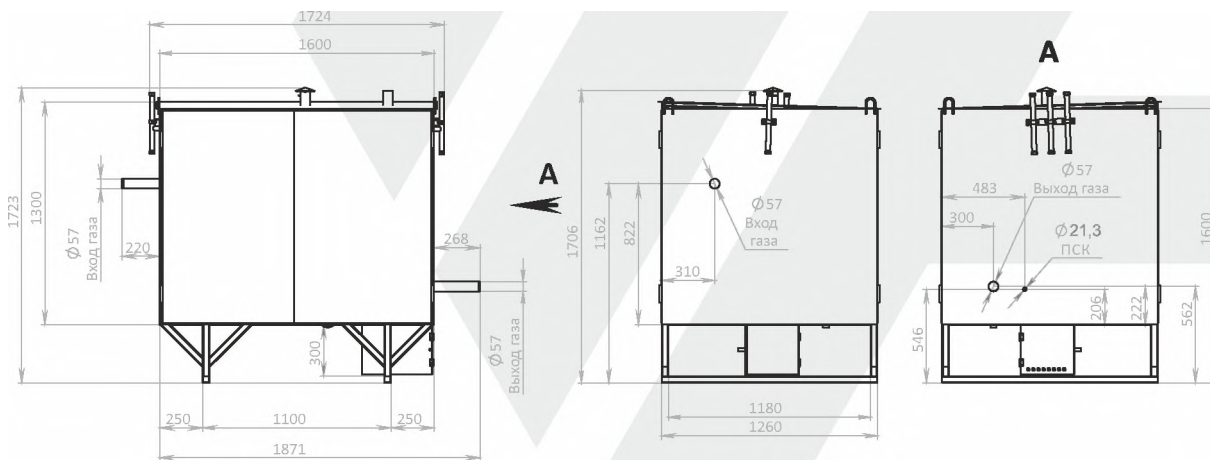

-01 1.5002 1-

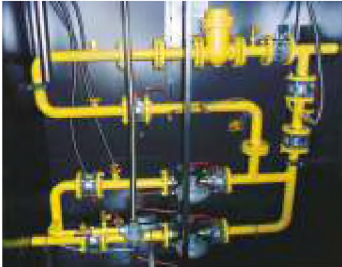

Λ

- 1 1.500-2 1- -

500 1.500 01 1.500
1,0 2,0

-40...+60

1,3 10,0 10,0 30,0 30,0 250,0

±5

3...18 1,8...45 55...400

0,6...6 10...50 10...200

/ 65 5/ 65 / 65

1,5-15 15-50 50-7000

!*

15

01 1500

100 / .

DIVAL-500 1 1

	15-100			5	100-300		TR 300-1000			TR 1000-3000		
	5	10	20		10	20	5	10	520	5	10	20
5 +°	50	75	100	100	140	150	50	80	100	100	160	200
+1,0	75	140	150	140	200	230	75	130	150	150	270	300
5 +2	120	200	240	200	300	300	120	200	250	300	480	500
+5,0	140	250	300	350	350	350	130	350	350	350	350	350

2

	15-100			5	100-300		300-1000			1000-3000		
	5	20	5		20	5	520	5	20	5	20	
+0,5	70	110	115	100	160	180	60	90	110	110	160	200
1,0+	160	170	180	160	240	280	75	140	160	180	350	400
+2,5	300	350	350	350	500	500	160	250	280	320	500	500
5,0+	200	250	300	300	500	500	350	450	500	350		

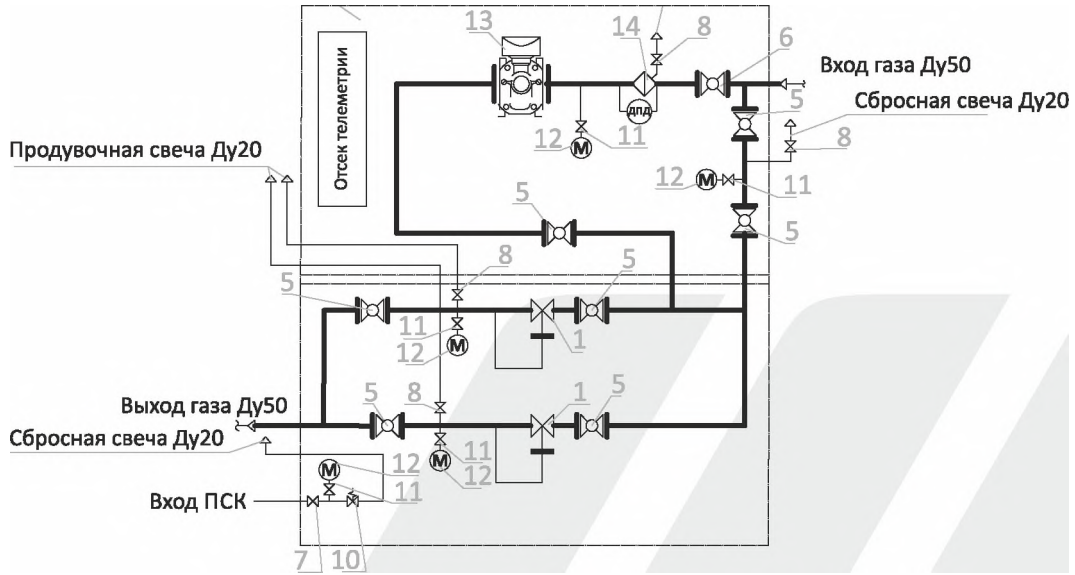

- 1 - ; 15; 8 - ; 13 - ; 20; 10 - ; 50; - ; ; 11 - ; 50; 7 - ; 12 - ; 14 - ; 50

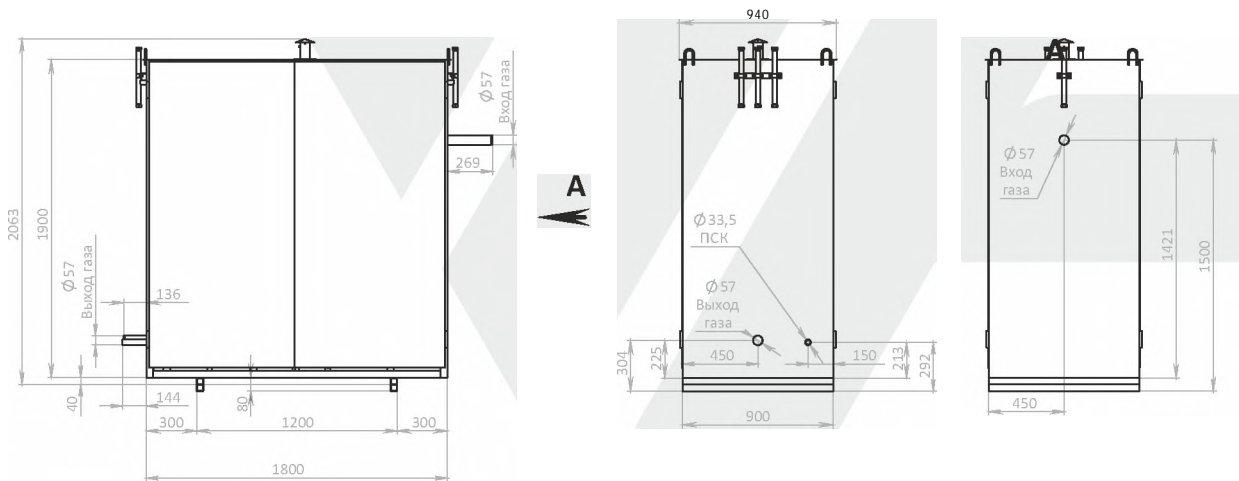

- 1\ 1.600-2 1- ()*

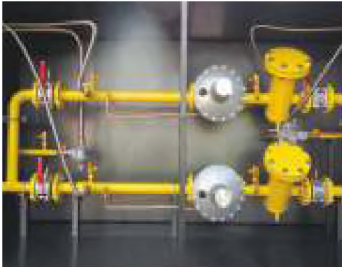

^_

		-01 1.600-2 1-	
01 1.600	01 1.600	01 1.600	
1,0		2,0	
		-40...+60	
1,0 12,0	1,0 35,0	28,0 440,0	
	±5		
3...18	14...45	25...550	
0,6...6	1...24	10...350	
/ 65	/ 65	5/ 65	
1,5-15	15-50	50-700	
	15		

1-
2-
0=0,526 gxP1 sinK. (^^^) (. 3') 0= 2+(, - 2) (3'),
2 < 2 > 2 = 0,52 1(. 3') = , (3');
() , . 3' () , 3' (\$); , \$ — ; 2—

	0 280				0 280			
	25	32	40	50	25	32	40	50
\$	269	300	652	781	315	334	692	770
	383	315	685	821	331	351	727	809
	94	95	94	86	97	97	95	97

*

-01 1.6002 1-



^_

-01 1.600-2 1- -0

01 1-600 01 1.600 01 1.600
1,0 2,0

-40...+60

1,0 12,0 10,0 35,0 28,0 440,0

±5

3...18 14...45 25...550

0,6...6 1...24 10...350

/ 65 5/ 65 5/ 65

1,5-15 15-50 50-700

!

15

1-
2-
 $0 = 0,526 \cdot \sin K \cdot (\wedge -) (\cdot \mathcal{Y})$ < 2 > 2 $2 = 0,526$ $(\cdot \mathcal{Y}) = , (\mathcal{Y}) ;$

$0 = // 2 + (, - \mathcal{Y}) (\mathcal{Y})$
 $(\quad) , \cdot \mathcal{Y} (\quad) , \mathcal{Y} (\quad) ; \quad \S -$
 $; , -$
 $; 2 -$

0 280

0 280

25	32	40	50	25	32	40	50
269	300	652	781	315	334	692	770
383	315	685	821	331	351	727	809
94	95	94	86	97	97	95	97

► Функциональная схема

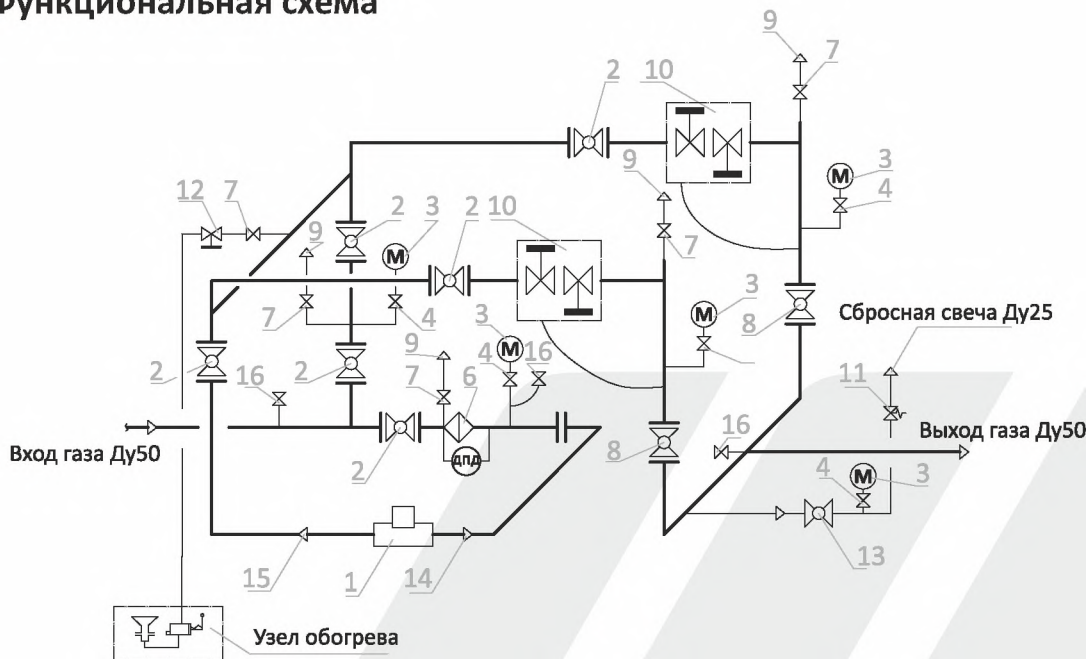

1 -	-2,0-160/1,6(1:160); 2 -	-50; 3 -	; 4 -	20 1,5
; 10 -	; 6 -	-50	; 7 -	80 ; 9 -
		0 1 600	1_ / 0 50; 11 -	√5/ 65 ; 12 -
	-1,1,2; 13 -		25; 14 -	50- 80; 15 -
				80- 50; 16 -

11641 27 1/2

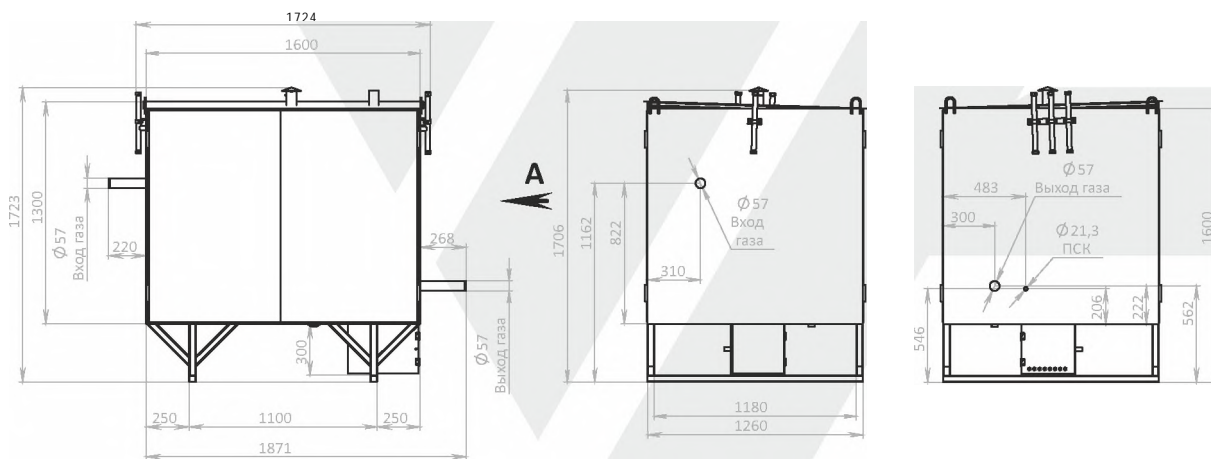

-01 1.6002 1-



^_

- 1 1.600-2 1- -

01 1.600	01 1.600	01 1.600
1,0		2,0
	-40...+60	
1,0 12,0	10,0 35,0	28,0 440,0
	±5	
3...18	14...45	25...550
0,6...6	1...24	10...350
/ 65	5/ 65	5/ 65
1,5-15	15-50	50-700

!
15

1-
2-
0=0,526 gxP1 sinK. ('^ -) (. 3') 0= // 2+(, - 2) (3'), () , . 3' () , 3' () ; , § — ; 2—

0 280

0 280

25	32	40	50	25	32	40	50
269	300	652	781	315	334	692	770
383	315	685	821	331	351	727	809
94	95	94	86	97	97	95	97

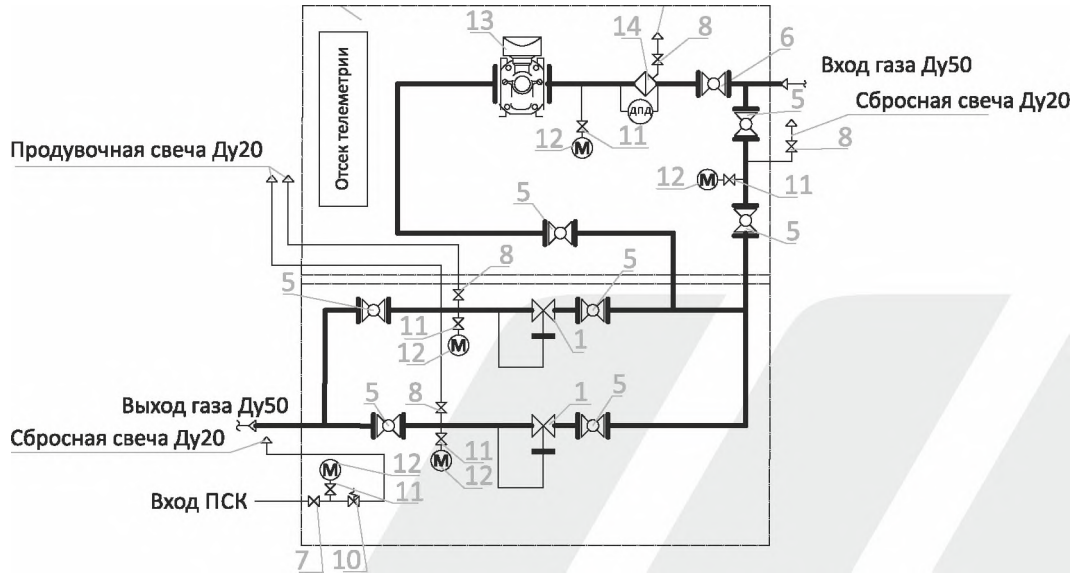

- 1 - ; 15; 8 - ; 1600 ; 5 - ; 20; 10 - ; 50; - ; ; 11 - ; 50; 7 - ; 12 - ; 13 - ; ; 14 - ; 50

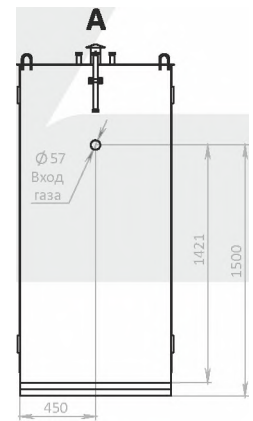
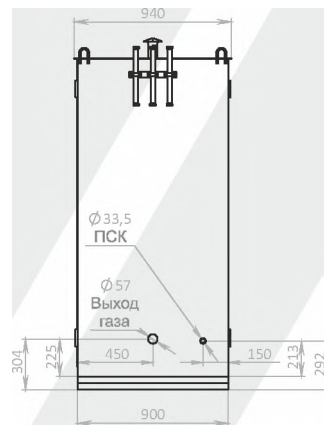
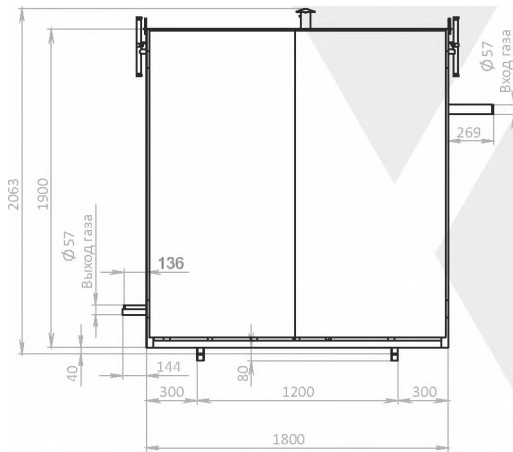

- 6/2 -2 1-



^_

- 6/2 -2 1-

/

0,6

{ }

-40...+60

2,0 40,0

±10

2-55

2,5-6

15

	2	0,05	0,1	0,2	0,3-0,4	0,5-0,6
	2,0	25	27	30	30	37
FRG/2MB	3,0	37	37	37	39	39
« »	5,0	50	50	50	50	50
DN 15	10,0	60	62	62	62	62
	20,0	85	85	85	85	85
	30,0	70	100	100	100	100
	2,0	42	42	50	50	50
FRG/2MB	3,0	50	50	55	55	55
« »	5,0	70	70	70	70	70
DN 20	10,0	100	100	100	100	100
	20,0	86	100	100	100	100
	30,0	86	100	100	100	100

*

FRG/2MB « » DN 25	2,0	100	100	100	100	100
	3,0	100	100	100	100	100
	5,0	100	100	100	100	100
	10,0	100	100	100	100	100
	20,0	100	100	100	100	100
	30,0	100	100	100	100	100

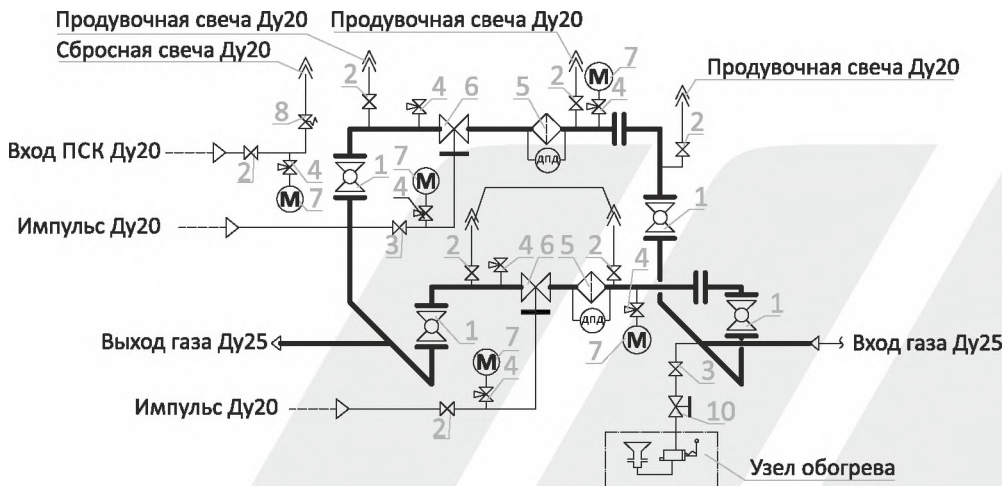

1 - ; 8 - ; 20; 3 - ; 15; 4 - ; 15; 5 - ; -25; 100/ ; 7 - ; -2; 1 0 -

► Габаритные размеры

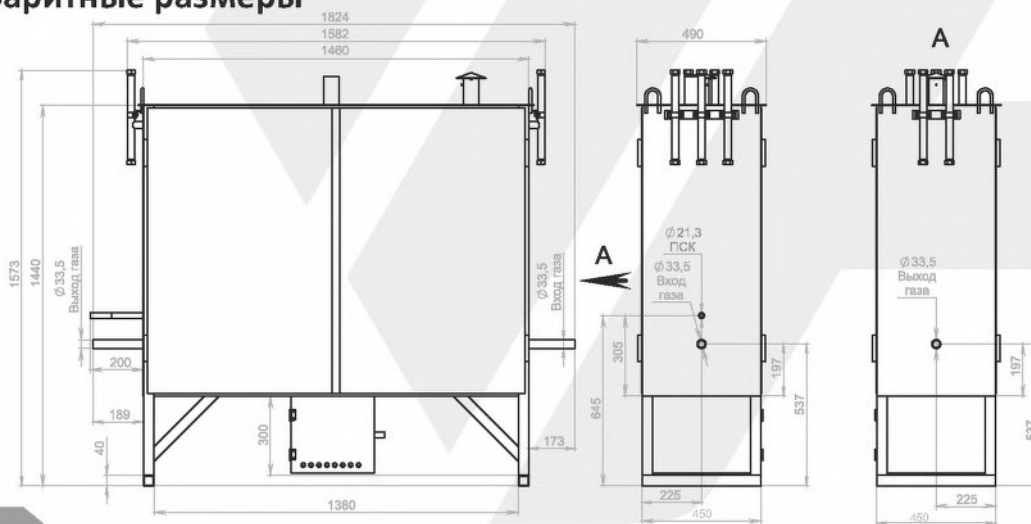

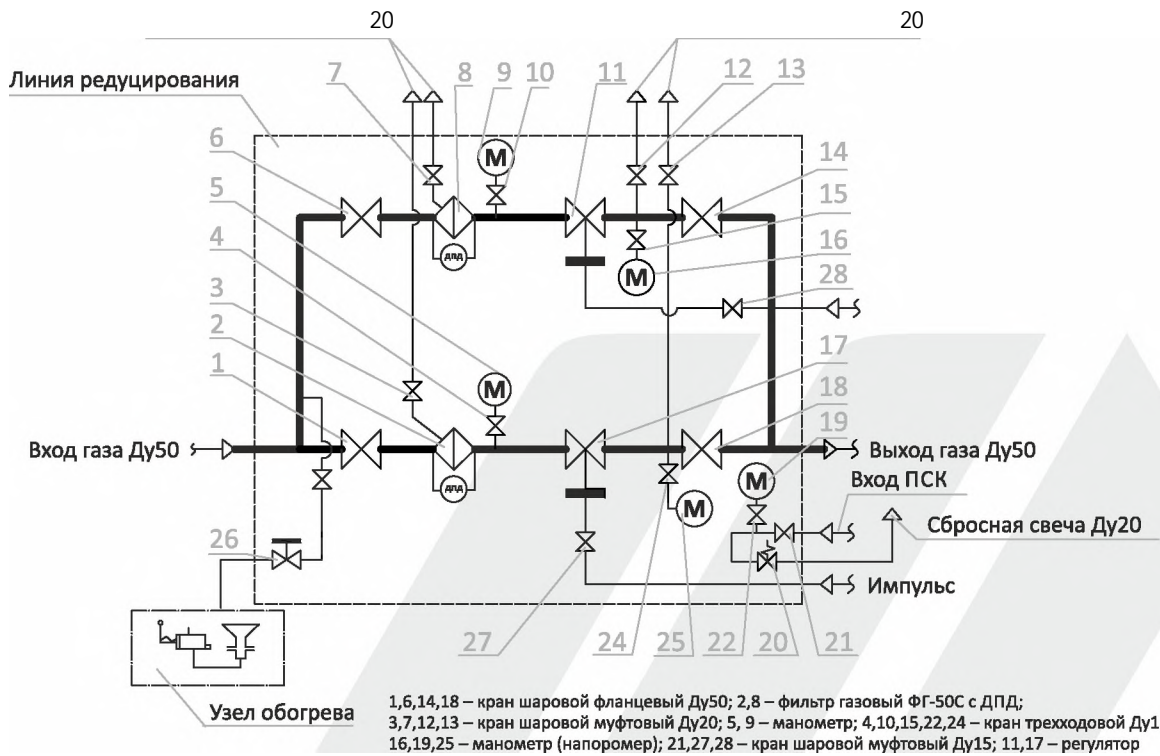

-50 ; 20 -

; 26 -

-1,2

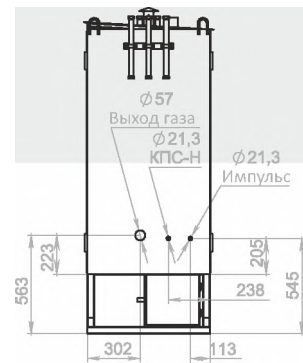
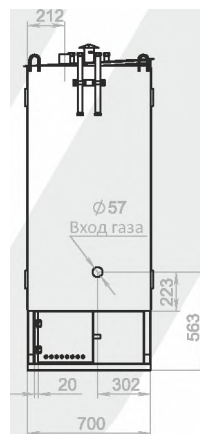
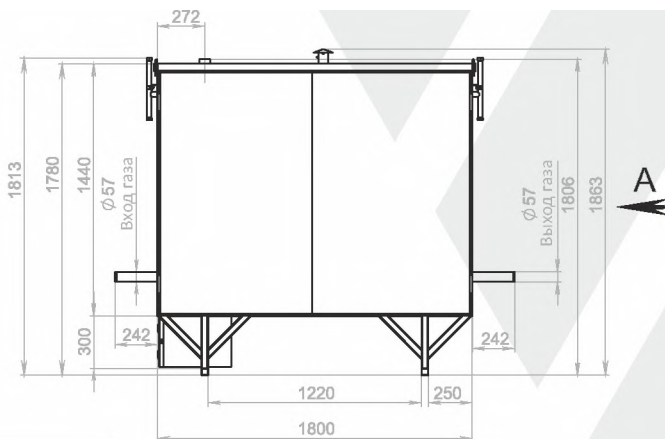

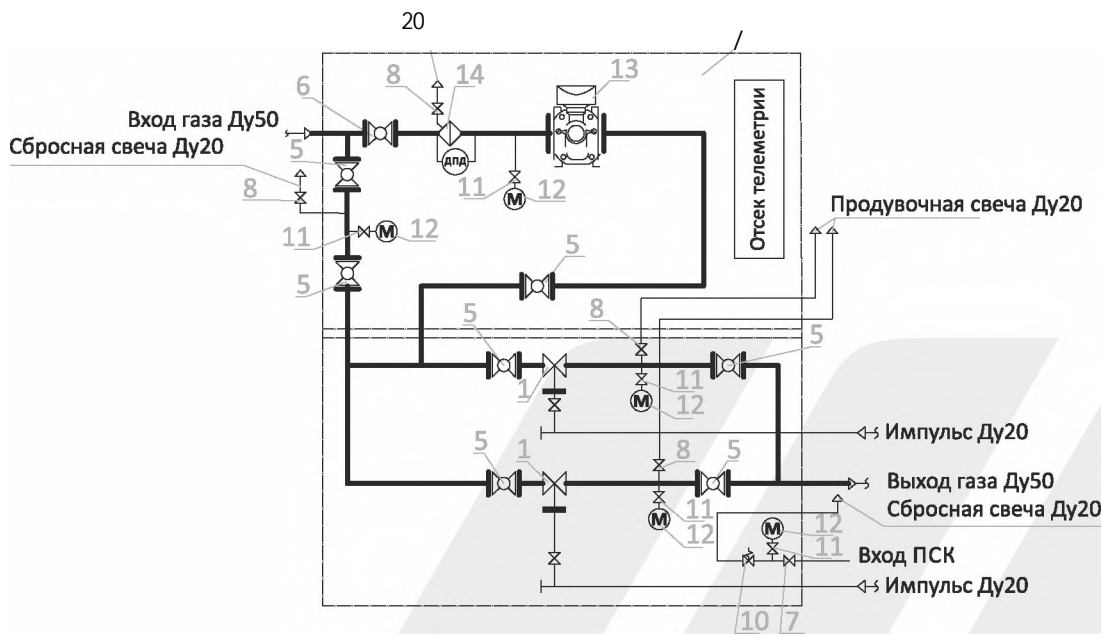

1 - ; 15; 8 - ; 50 ; 5 - ; 20; 10 - ; 50; - ; ; 11 - ; 50; 7 - ; 12 - ; 13 - ; 14 - ; 50

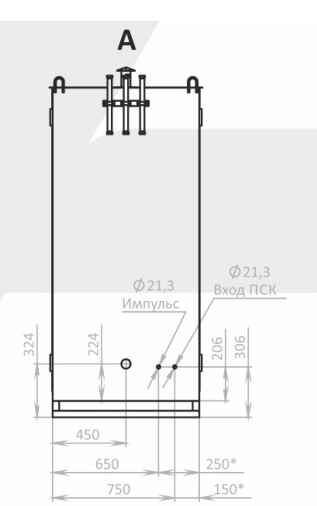
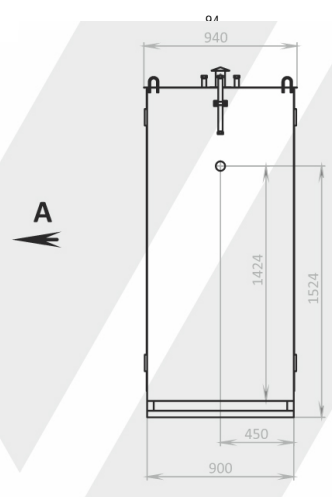
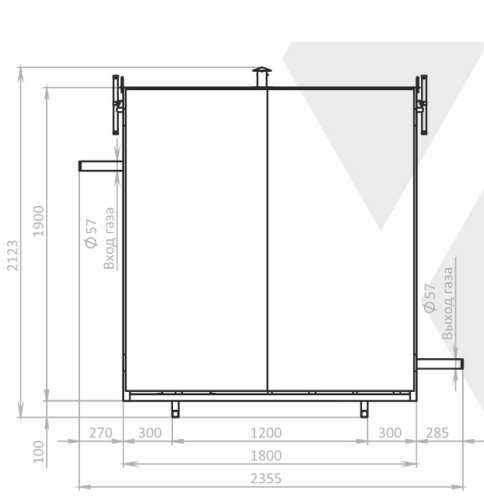

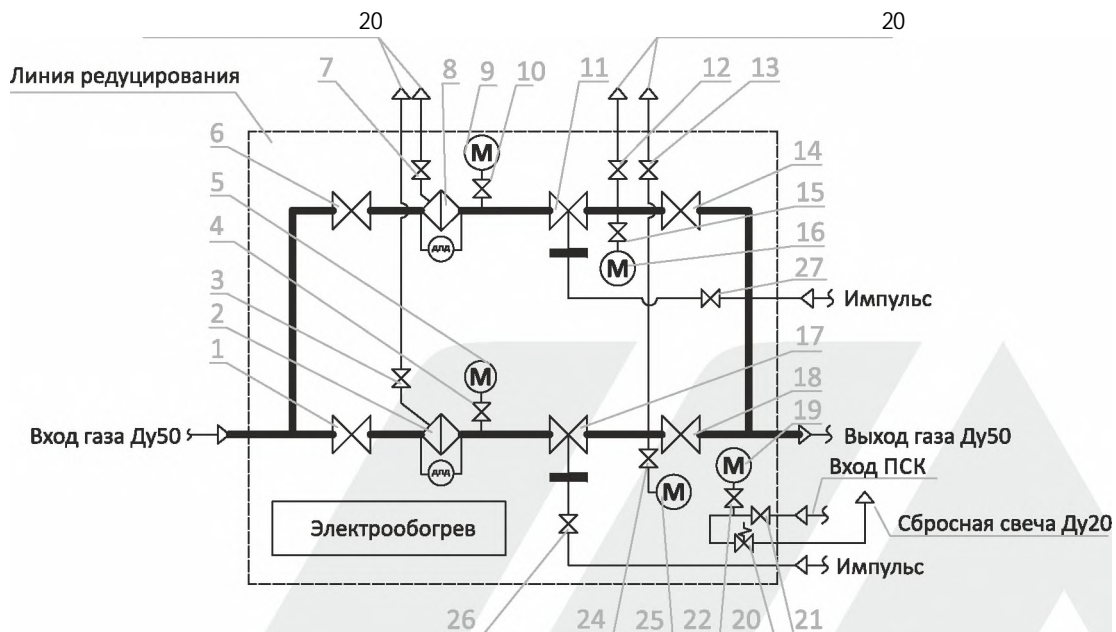

1,6,14,18 -
4,10,15,22,24 -

-50 ; 20 -

50; 2,8 -
15; 16,19,25 -

(-50 ; 3,7,12,13 -
) ; 21,26,27 -

20; 5, 9 -
15; 11,17 -

- 2 1-

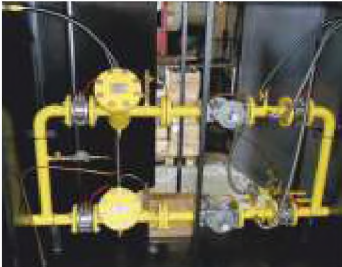

- 2 1-

-50

1,2

5542-87

-40...+60

270-300

±10

(1,2...1,5)

(0,3...0,5)

- -2

50-360

15

, , 3'

0,05 0,1 0,2 0,3 0,4 0,5 0,6 0,7 0,8 0,9 1,0 1 1,2

-50

-

450 600 750 800 850 900 1000 1100 1200

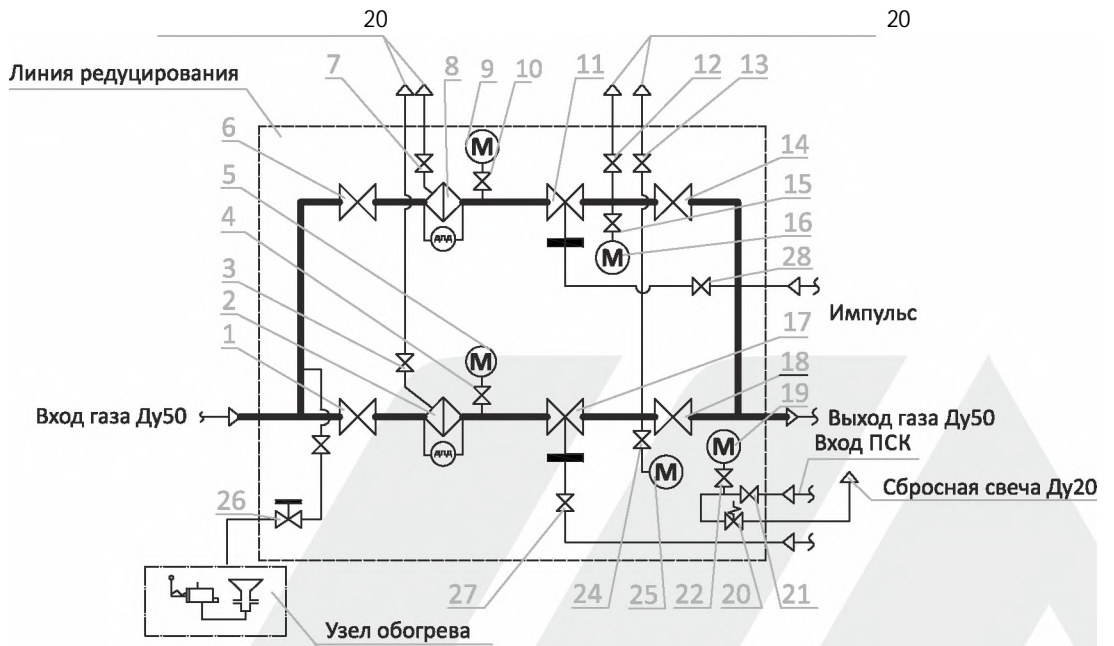

1,6,14,18 -
4,10,15,22,24 -

-50 ; 20 -

50; 2.8 -
15; 16,19,25 -

(

-50 ; 3,7,12,13 -
); 21,27,28 -

; 26 -

-1,2

20; 5, 9 -
15; 11,17 -

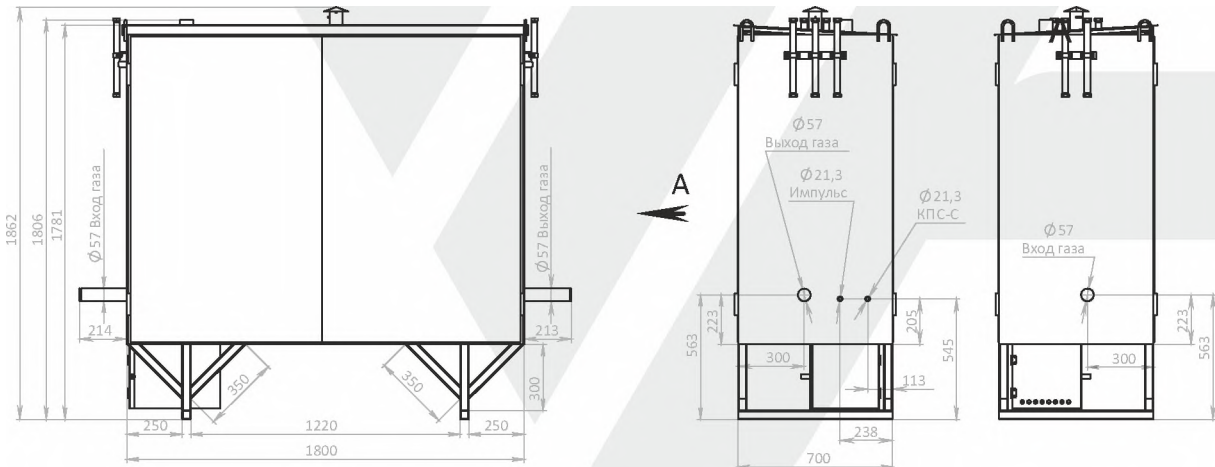

03 -2 1- -0



- -2 1- -
-50
1,2
5542-87
-40...+60
270-300
±10
(1,2...1,5)
(0,3...0,5)
- -2
50-360

15

	0,05	0,1	0,2	0,3	0,4	0,5	0,6	0,7	0,8	0,9	1,0	1	1,2
-50					450	600	750	800	850	900	1000	1100	1200

► Функциональная схема

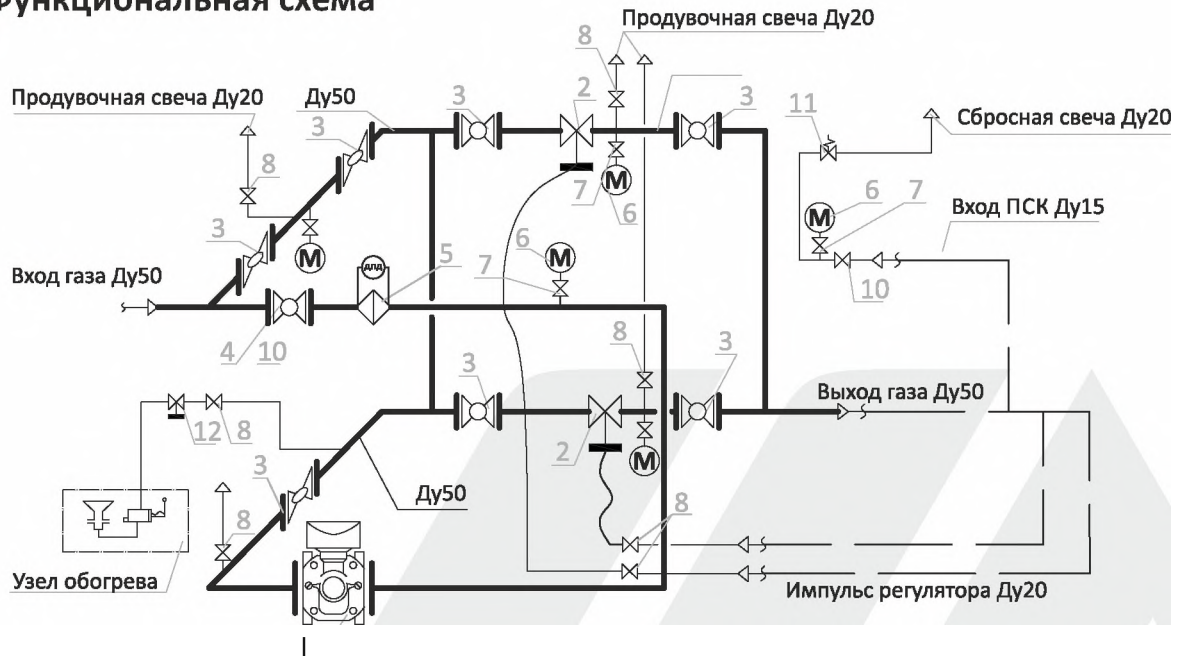

1 - 50 ; 2 - -50 ; 3 - 50 ; 4 - 50 ; 5 - 15 ; 6 - -50 ; 7 - 15 ; 8 - 15 ; 10 - 20 ; 11 - 15 ; 12 - -1,2

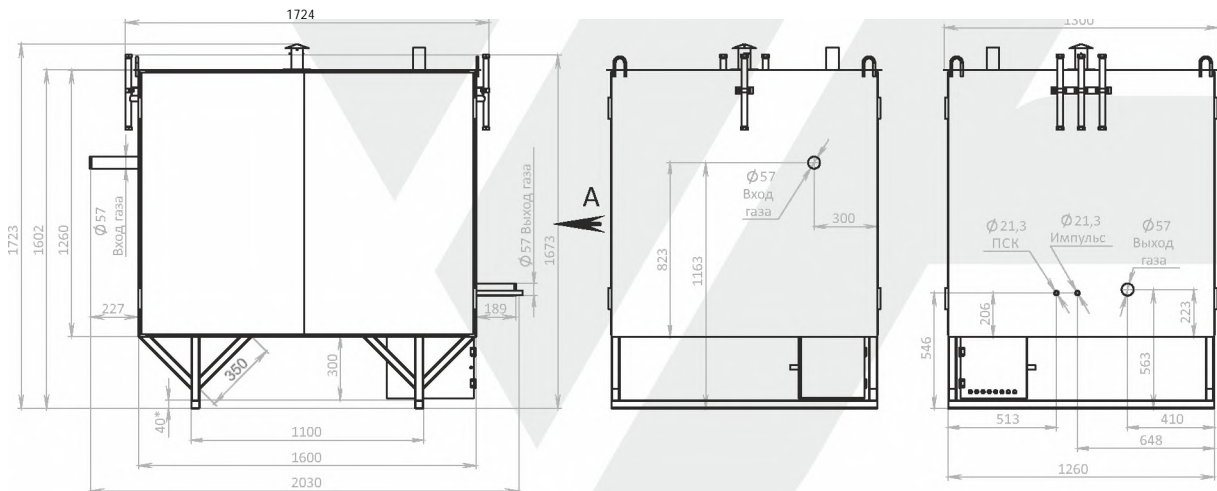

2 1



- 2 1- -
-50
1,2
5542-87
-40...+60
270-300
±10
(1,2...1,5)
(0,3...0,5)
- -2
50-360

15

3'

	0,05	0,1	0,2	0,3	0,4	0,5	0,6	0,7	0,8	0,9	1,0	1	1,2
-50					450	600	750	800	850	900	1000	1100	1200

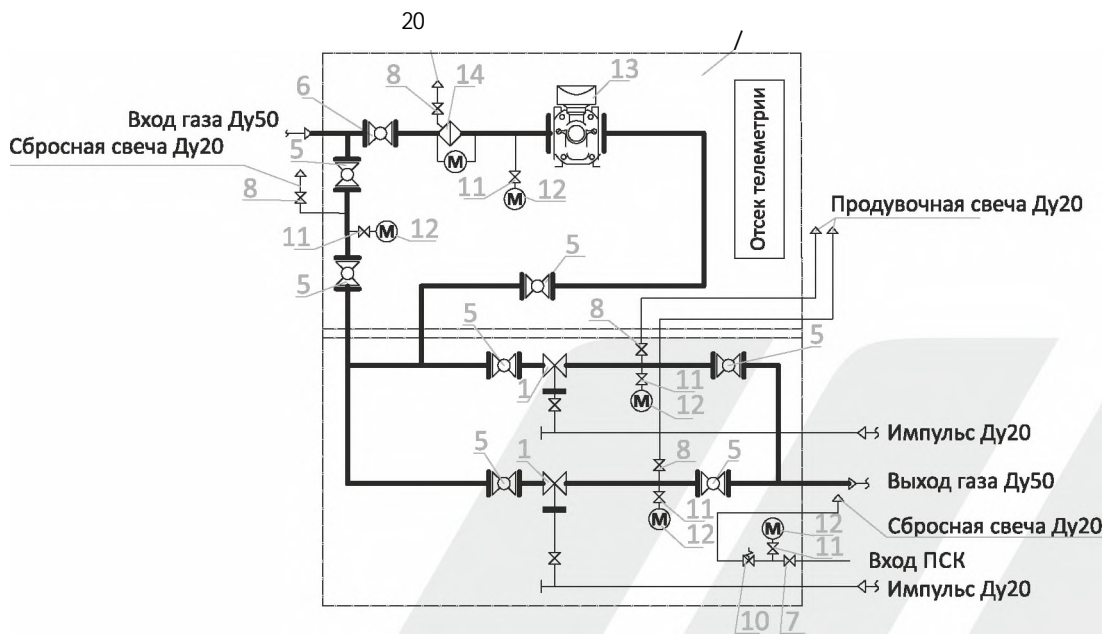

1 - ; 5 - ; 20; 10 - ; 50; - ; ; 11 - ; 50; 7 - ; 12 - ; 15; 8 - ; 13 - ; 14 - ; 50

- 2 1-

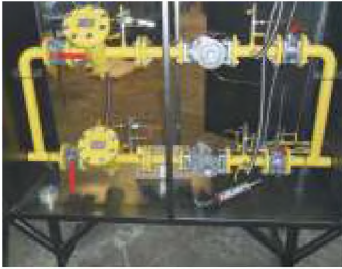

- 2 1-

-50

1,2

5542-87

-40...+60

270-300

±10

(1,2...1,5)

(0,3...0,5)

- -2

50-360

15

3'

0,05 0,1 0,2 0,3 0,4 0,5 0,6 0,7 0,8 0,9 1,0 1 1,2

-50

-

450 600 750 800 850 900 1000 1100 1200

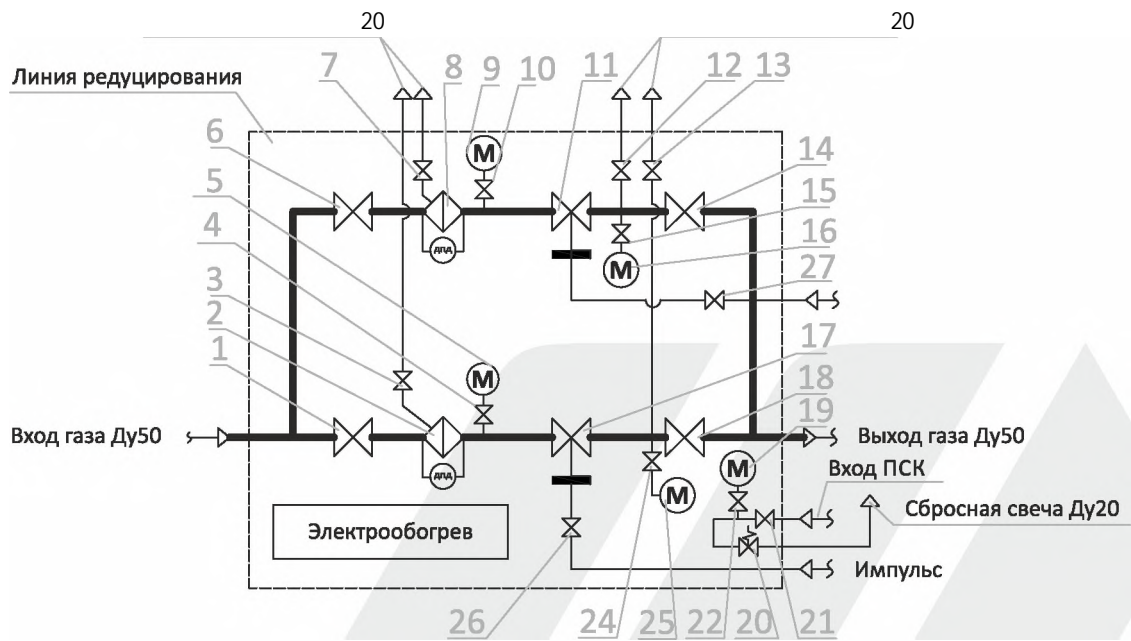

1,6,14,18 -
4,10,15,22,24 -

-50 ; 20-

50; 2,8 -
15; 16,19,25 -

26 24 25 22 20 21
(-50 ; 3,7,12,13 -
) ; 21,26,27 -

20; 5, 9 -
15; 11,17 -

-04-2 1- ()*



-04-2 1-
 -400 -50/400
 0,6
 5542-87
 -40...+60
 2-5
 ±10
 (1,2...1,8) (2,5...6,3)
 (0,2...0,5) (0,6...1,1)
 - -1
 2,5- ,0
 15

	0,05	0,1	0,2	0,3	0,4	0,5	0,6	0,7	0,8	0,9	1,0	1	1,2
-400	45	80	125	170	200	250							
-50/400	130	180	270	360	450	540	630						

*

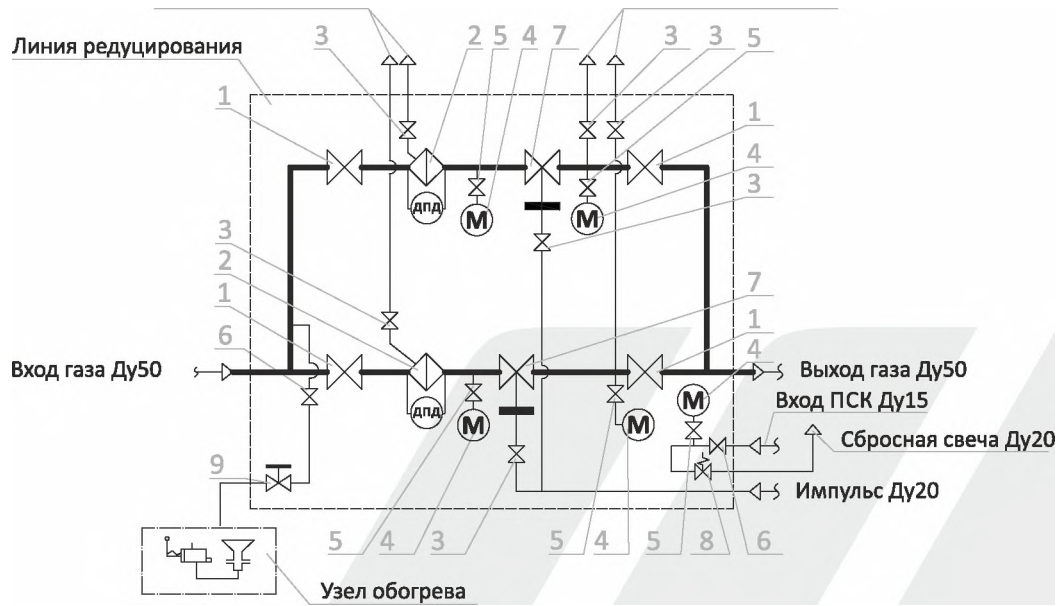

1 -
15
9 -

50; 2 -
;
-1-1,2

-50 ; 3 -
15; 7 -

25; 4 - ; 5 -
-400; 8 -

ГРПШ-04-2У1-ЭК-ОГ(ЭО)*

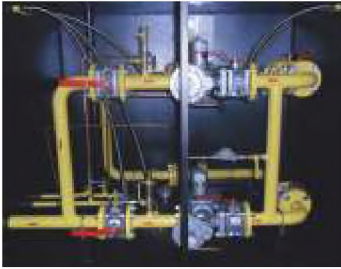

-400 -04-2 1- -50/400

0,6

5542-87

-40...+60

2-5

±10

(1,2...1,8)

(2,5...6,3)

(0,2...0,5)

(0,6...1,1)

- 1

2,5- 0

15

3'

	0,05	0,1	0,2	0,3	0,4	0,5	0,6	0,7	0,8	0,9	1,0	1	1,2
-400	45	80	125	170	200	250							
-50/400	130	180	270	360	450	540	630						

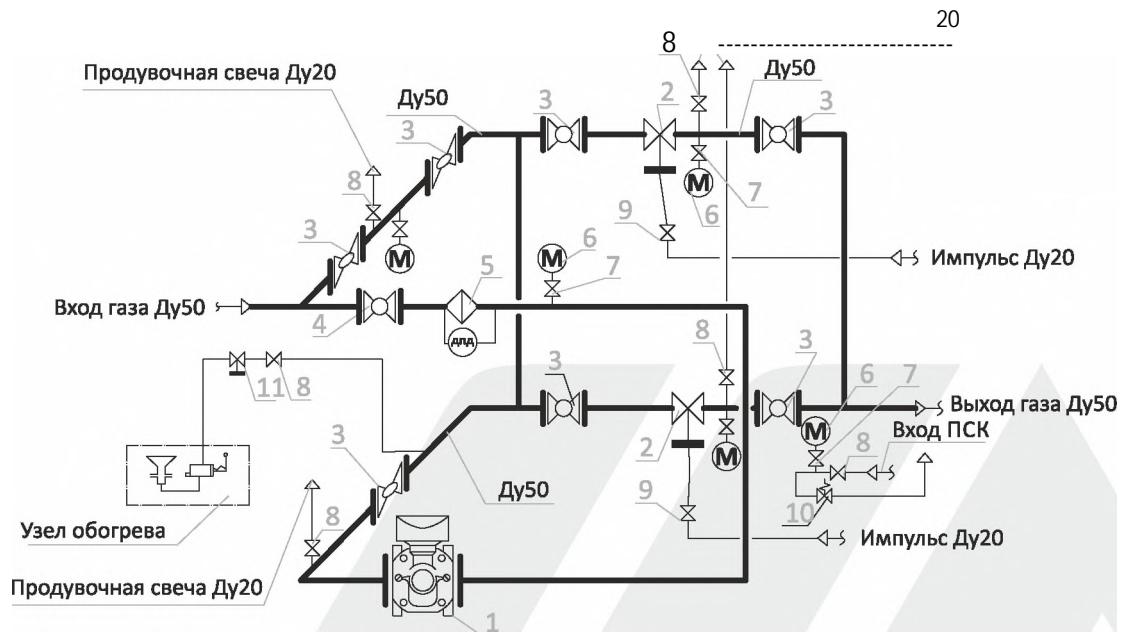

- 1 - (1 V); 2 - -400; 3 - 50;
 4 - 15 ; 5 - -50 ; 7 - ; 8 - ; 10 - ; 11 - ; 12 - -1,2

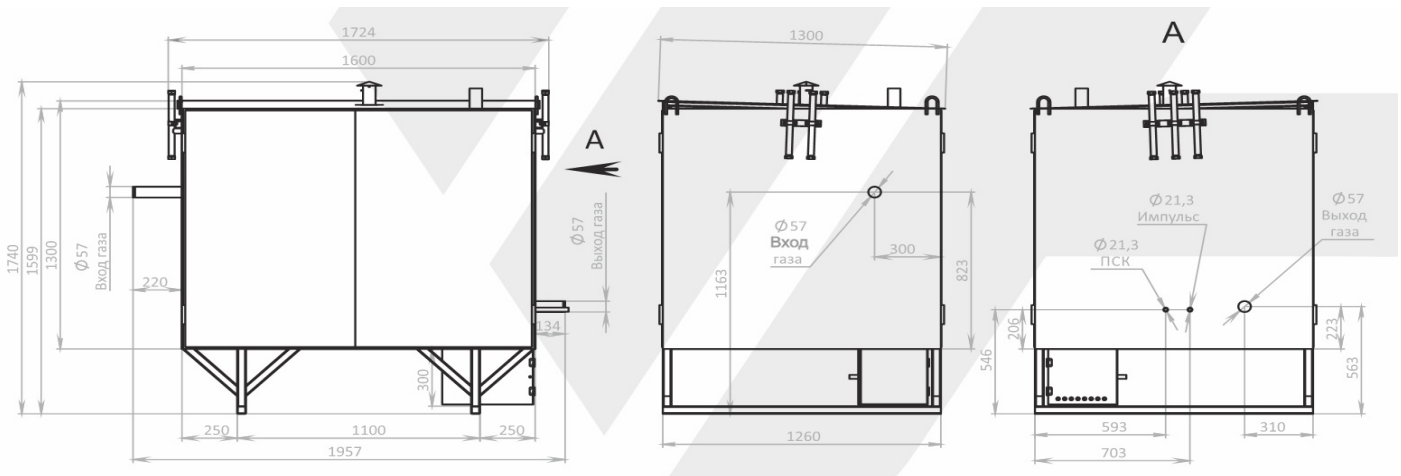

ГРПШ-05-2У1-ОГ(ЭО)*



-05-2 1-
-400
0,6

5542-87

-40...+60
2-5
±10

(1,2...1,8)
(0,2...0,5)

- 1

2,5- 0

15

*

3'

	0,05	0,1	0,2	0,3	0,4	0,5	0,6	0,7	0,8	0,9	1,0	1	1,2
-400	55	100	180	300	400	500	600						

*

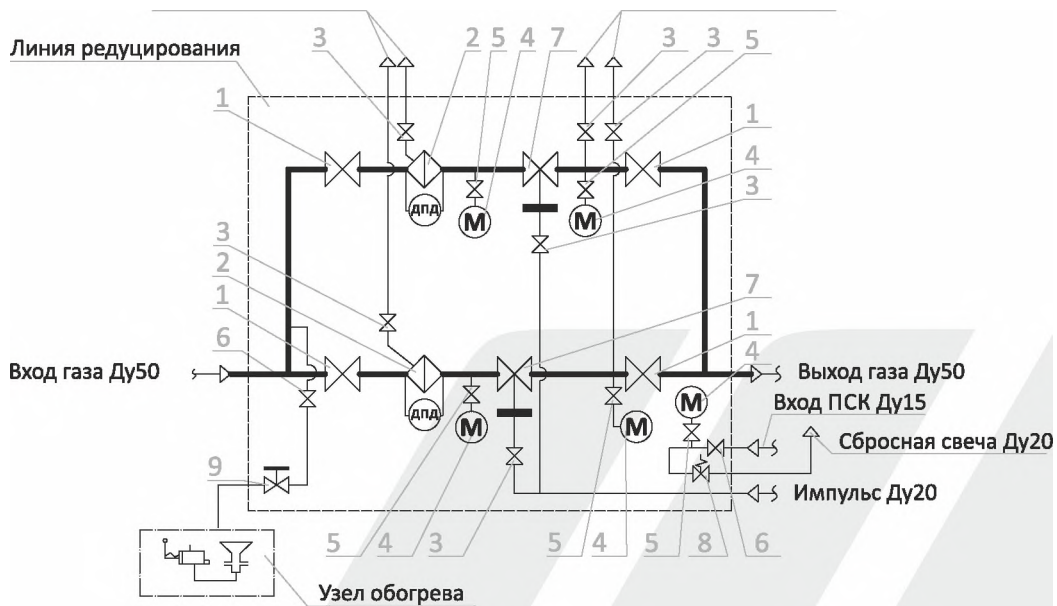

1 -
15
9 -

50; 2 -
; -
-1-1,2

-50 ; 3 -
15; 7 -

25; 4 -
-400 ; 8 -

; 5 -

-05-2 1- - ()*

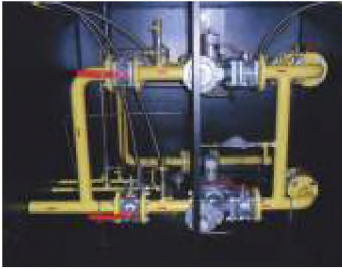

-05-2 1- -
-400
0,6

5542-87

-40...+60
2-5
±10

(1,2...1,8)
(0,2...0,5)

- -1

2,5- ,0

15

	0,05	0,1	0,2	0,3	0,4	0,5	0,6	0,7	0,8	0,9	1,0	1	1,2
-400	55	100	180	300	400	500	600						

*

ГРПШ-07-2У1-ОГ(ЭО)*



		-07-2 1-
	-1000	-50/1000
		0,6
		5542-87
		-40...+60
		2,0-5,0
		±10
	(1,2...1,8)	(2,5...1,1)
	(0,2...0,5)	(0,6...6,3)
		- 1
		2,5- 0
		15

	3'												
	0,05	0,1	0,2	0,3	0,4	0,5	0,6	0,7	0,8	0,9	1,0	1	1,2
-100	70	130	280	450	600	700	900				-		
-50/1000	216	300	450	600	750	900	1050				-		

*

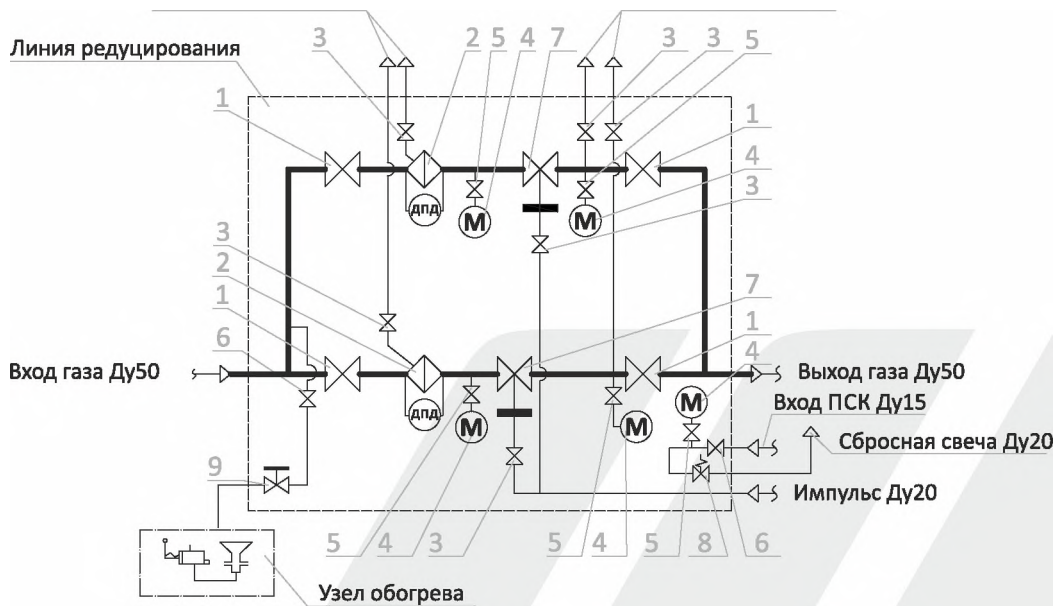

1 - 50; 2 - -50 ; 3 - 25; 4 - ; 5 -
 15
 9 - -1-1,2 ; 15; 7 - -1000; 8 - ;

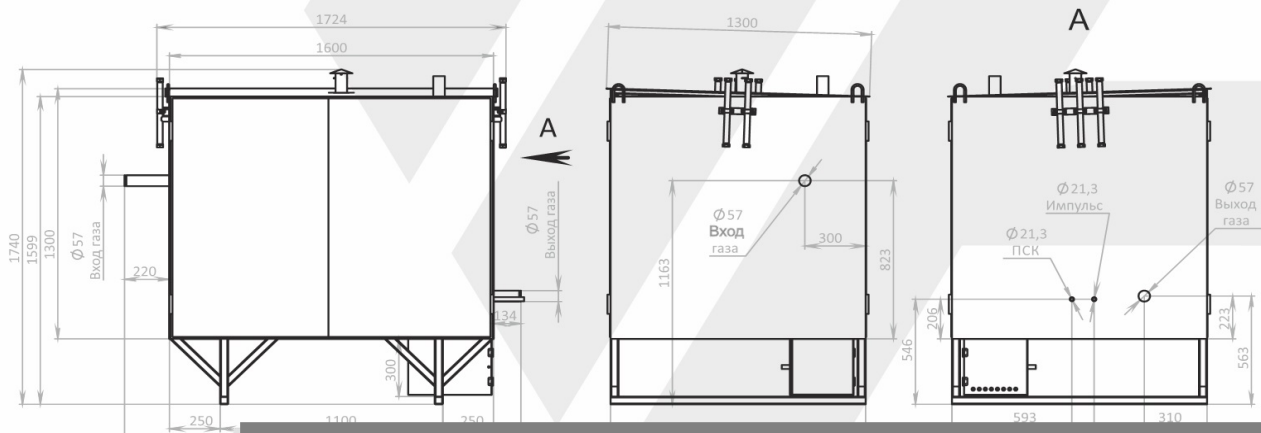

ГРПШ-07-2У1-ЭК-ОГ(ЭО)*



-1000 -07-2 1- -50/1000
 0,6
 5542-87
 -40...+60
 2,0-5,0
 ±10
 (1,2...1,8) (2,5...1,1)
 (0,2...0,5) (0,6...6,3)
 - -1
 2,5- ,0
 15

	0,05	0,1	0,2	0,3	0,4	0,5	0,6	0,7	0,8	0,9	1,0	1	1,2
-100	70	130	280	450	600	700	900						
-50/1000	216	300	450	600	750	900	1050						

*

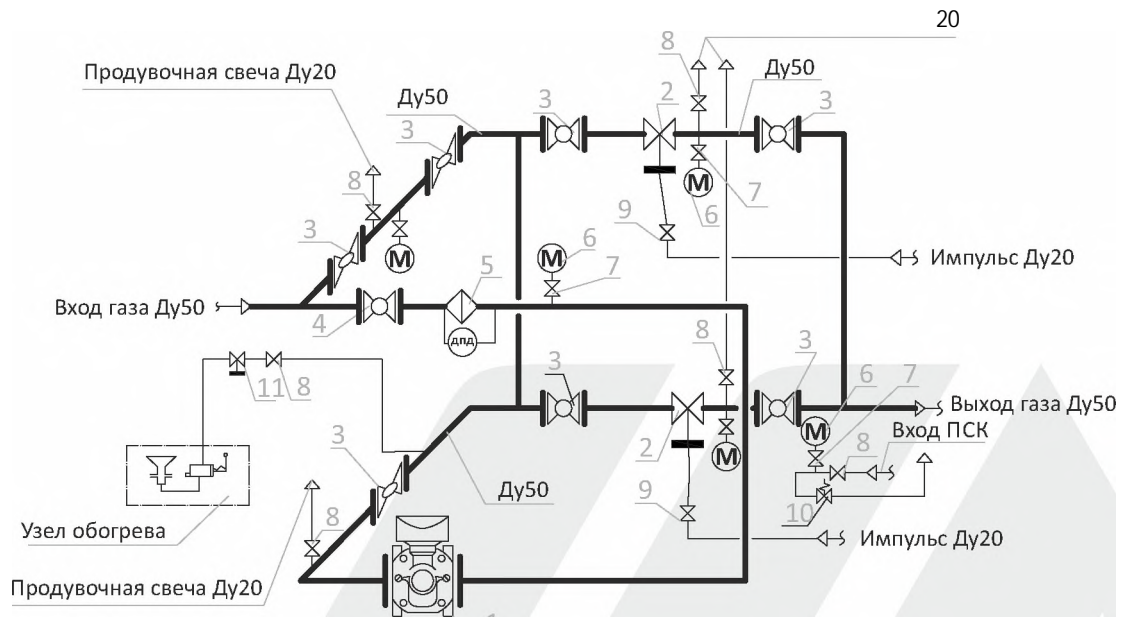

- 1- () ; 2- -1000; 3- 50;
 4- 15 ; 5- -50 ; 6- ; 7- ;
 ; 8- -1,2 ; 9- 20 ; 10- 15 ; 11-

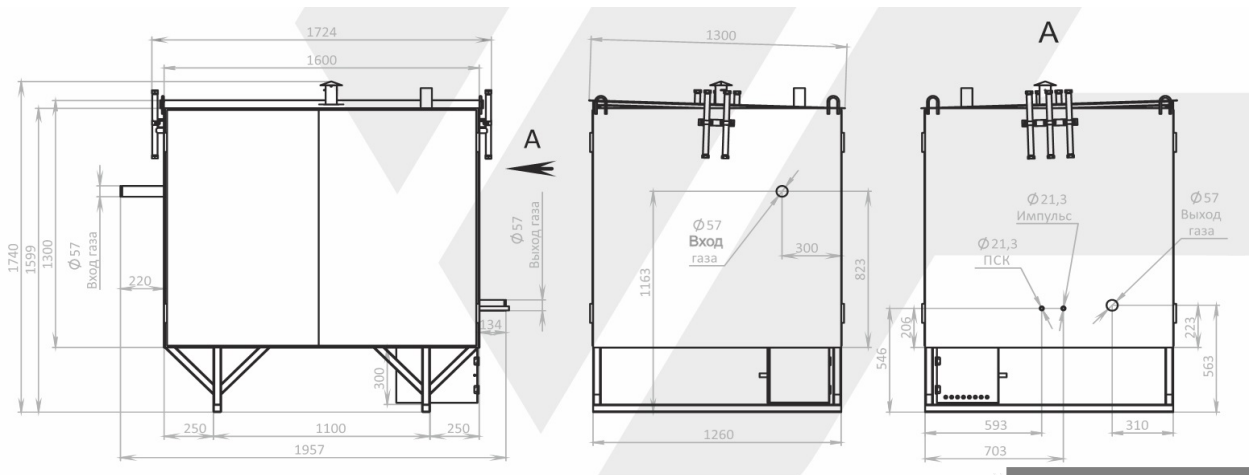

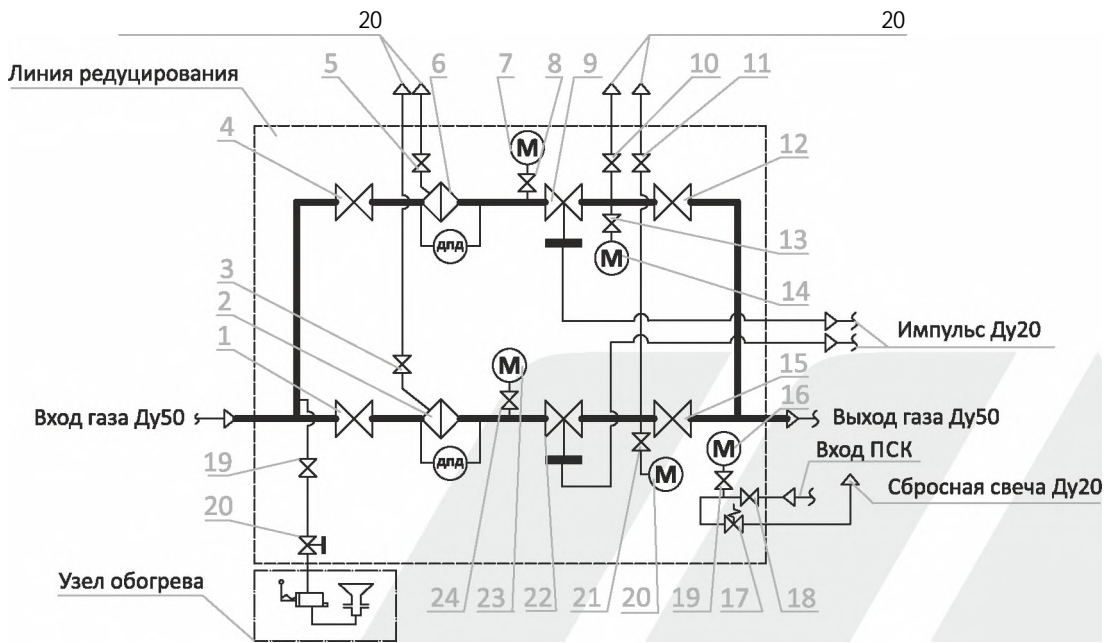

1,4 - ; 8,13,19,21 - ; 15; 19 - ; 15; 20 - ; 2,6 - ; 32; 2,5,10,11 - ; 20; 7,14,16,20,23 - ; 18 - ; -32/ -4-12; 17 - ; -1-1,2

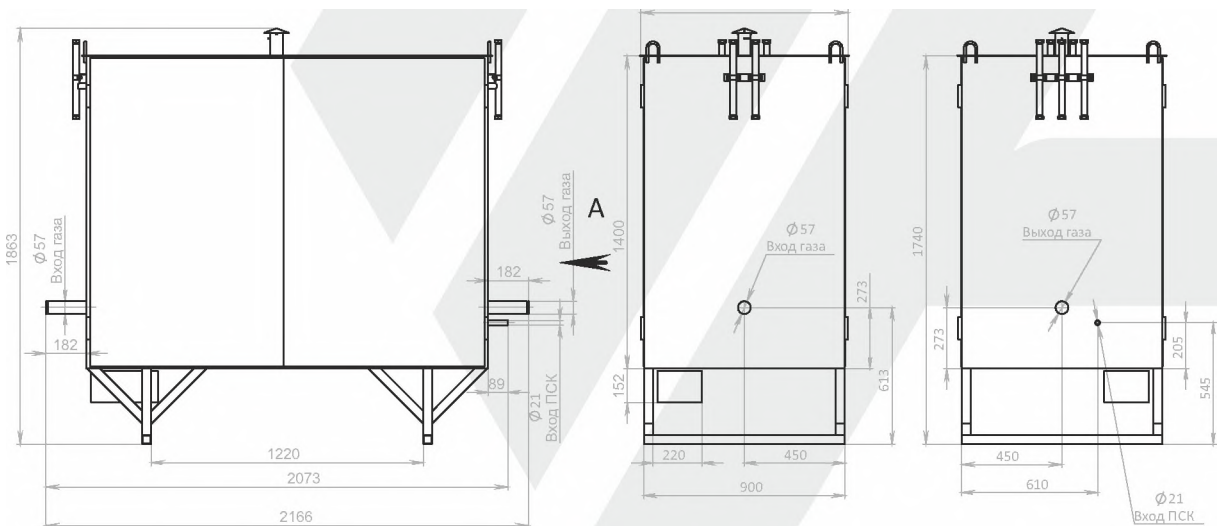

2 08 1

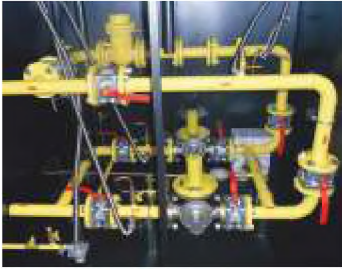

^_

-08-2 1- -

-32/ 1- 4-1,2	-32/ 1- 6-1,2	-32/ 1- 10-0,3	-32/ 2- 4-1,2	-32/ 2- 6-1,2	-32/ 2- 10-0,3	-32/ - 4-1,2	-32/ - 6-1,2	-32/ - 10-0,3
------------------	------------------	-------------------	------------------	------------------	-------------------	-----------------	-----------------	------------------

1,2	1,2	0,3	1,2	1,2	0,3	1,2	1,2	0,3
-----	-----	-----	-----	-----	-----	-----	-----	-----

5542-87

-40...+60

1-2	1-2	1-2	2-3,5	2-3,5	2-3,5	3,5-5	3,5-5	3,5-5
-----	-----	-----	-------	-------	-------	-------	-------	-------

30 %

±10

(1,2...1,8)

(0,2...0,5)

- -1

1,25-2,5

2,5 6,0

[*
15

3'

	0,05		0,2	0,3	0,4	0,5	0,6	0,7	0,8	0,9	1,0	1	1,2
-32	0 4	12	23	31	43	52	62	72	85	100	110	125	150
-32	0 6	23	35	65	77	97	129	155	174	206	232	258	300
-32	0 10	28	50	90	124								

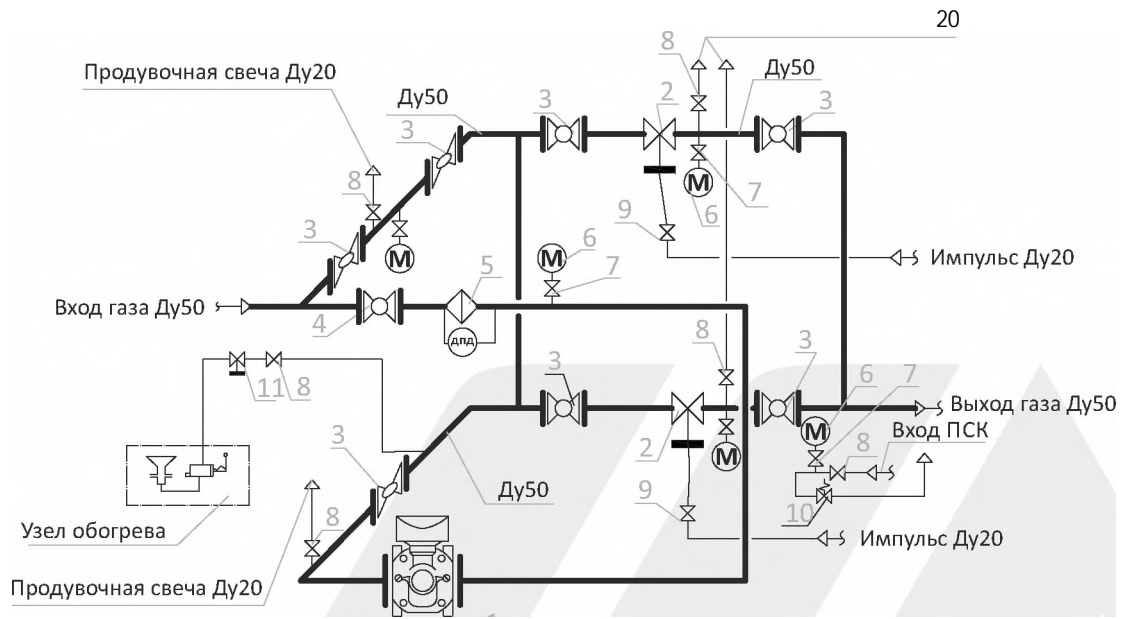

1 - 50 (; 2 - -32; 3 - 50; 4 - 15 ; 8 - ; 11 - ; 5 - 20; 9 - -50 ; - ; 7 - 15; 10 - - ; -1,2

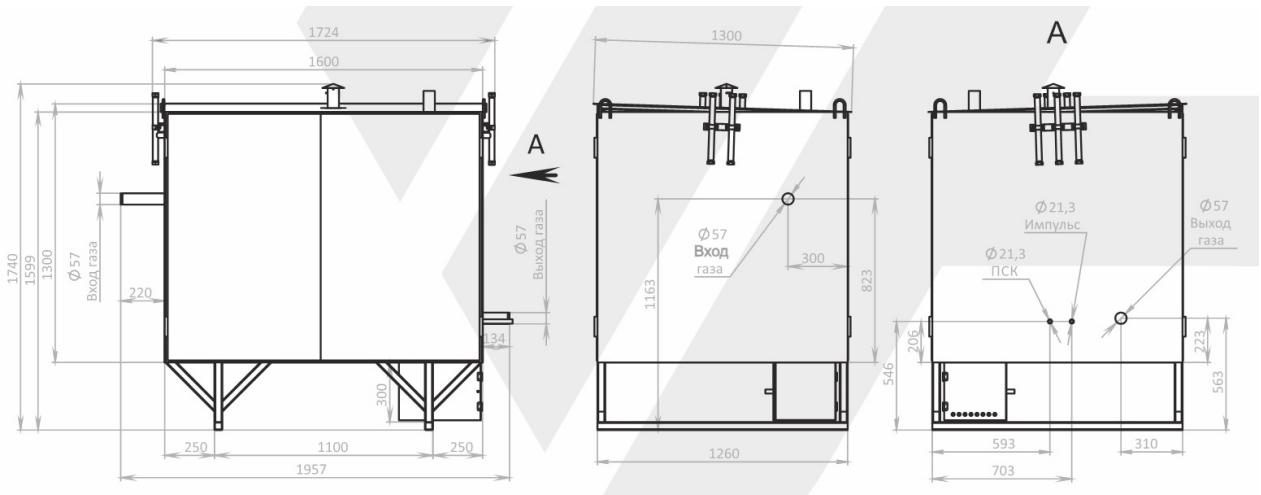

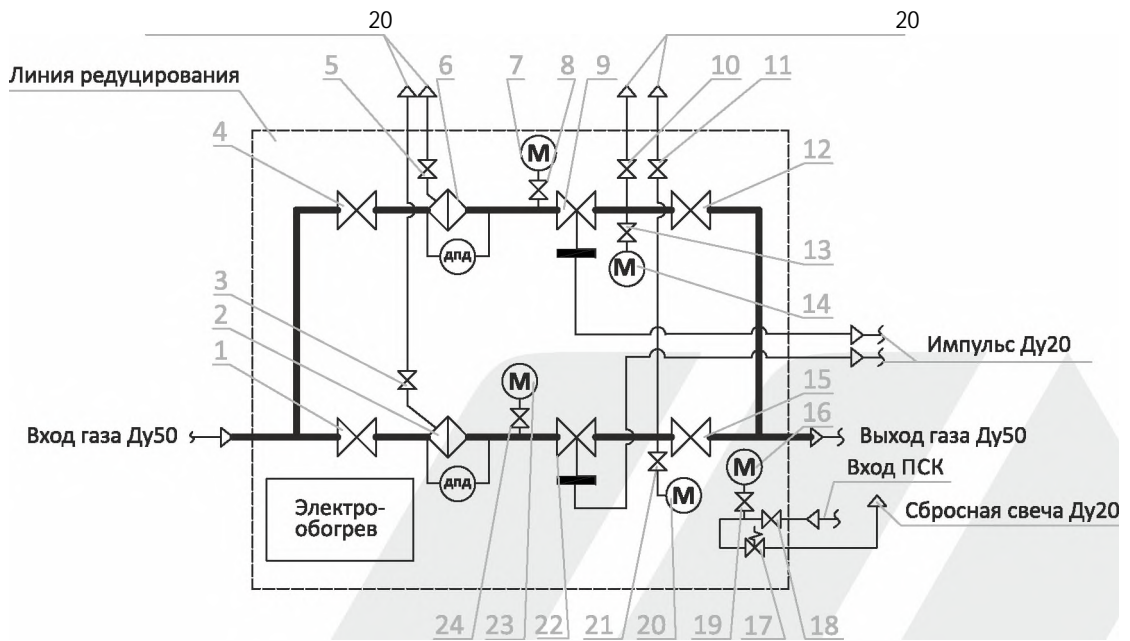

1,4 - 32; 2 - -32; 12,15 - 50; 26 - 32; 3,5,10,11 -
 20; 7,14,16,20,23 - ; 8,13,19,21 - 15 15; 9,22 - -32/ -4-1,2; 17 -
 ; 18 -

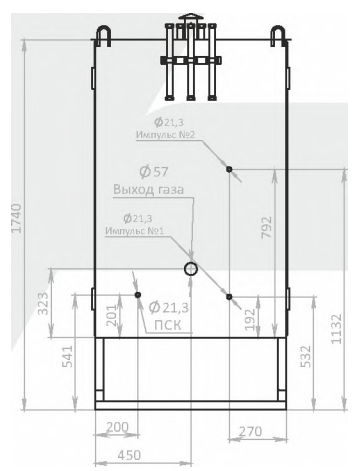
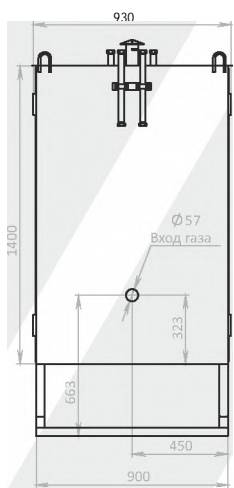
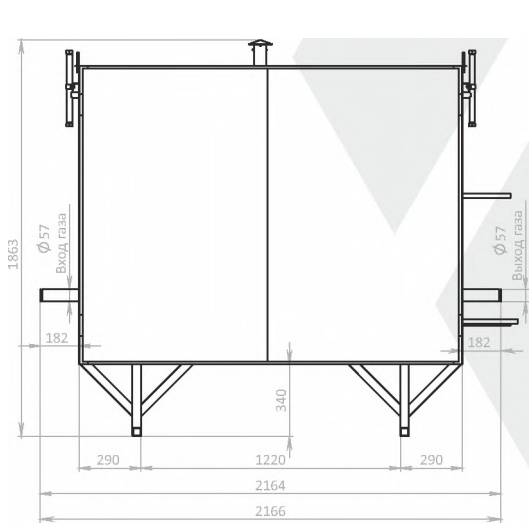

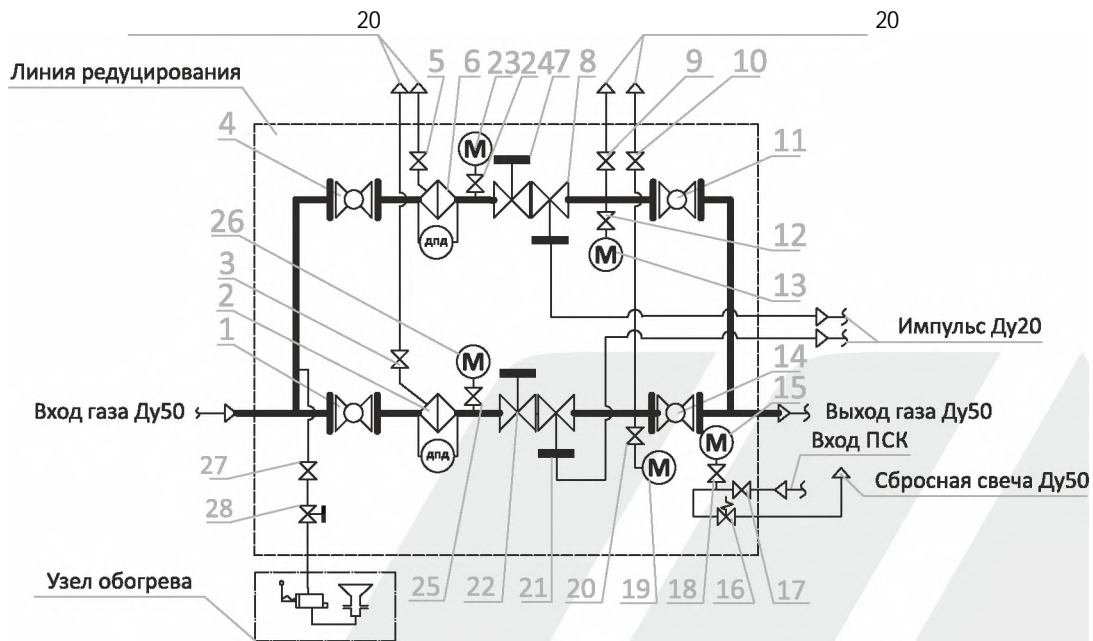

1,4,11,14,17 - 50; 2,6 - -50 ; 3,5,9,10 - 20; 7,22 -
 () ; 16 - ; 8,21 - ; 23,26 - ; 27 - ; 15; 28 - 15; 13,15,19 - -1-1,2

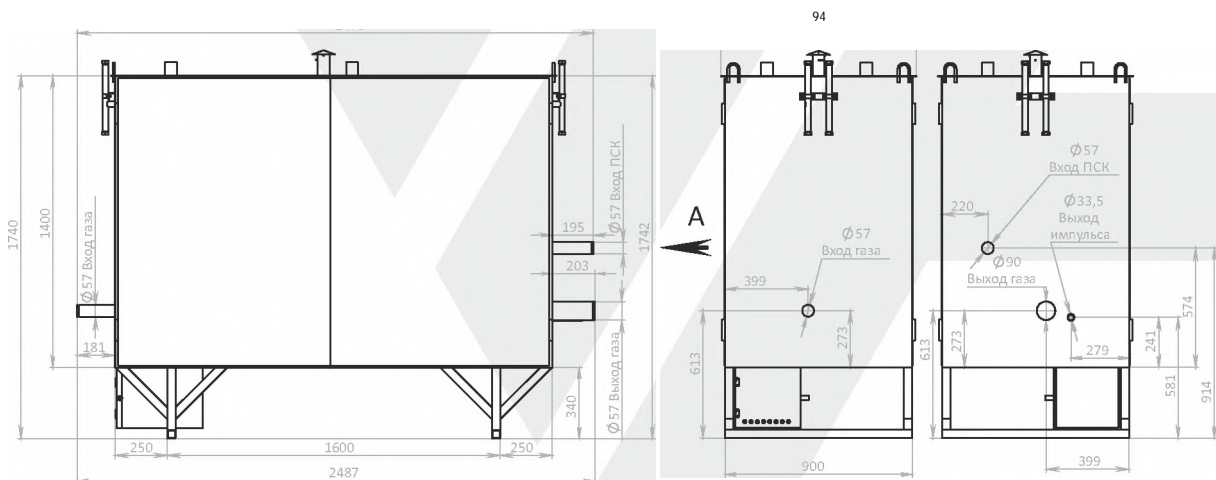

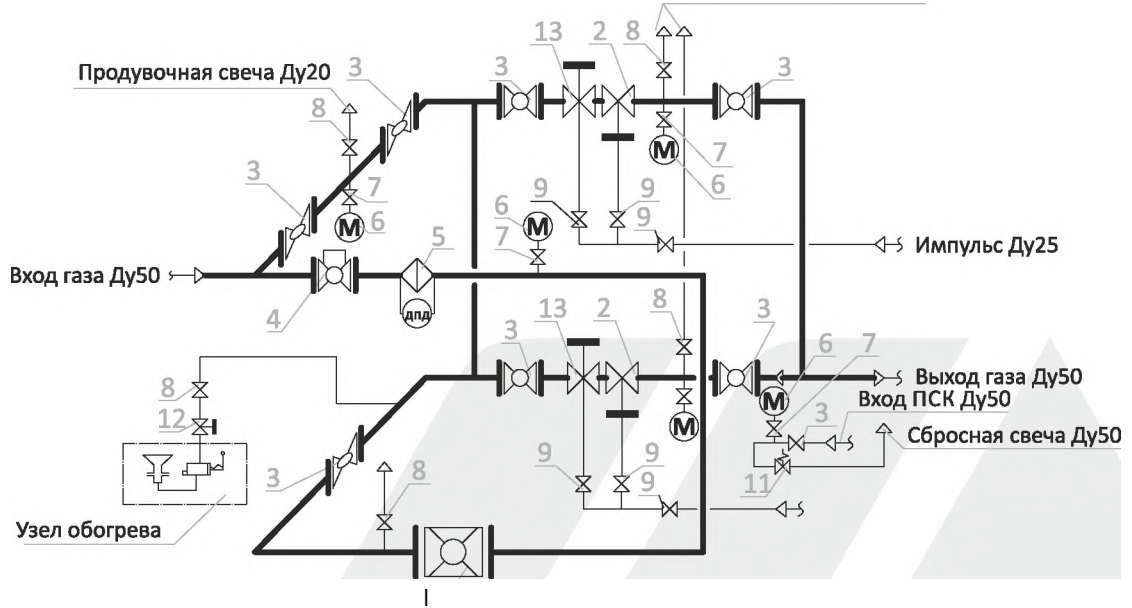

- 1 - 50 ; 5 - 25; 10 - -50 ; 2 - -50 ; 7 - 15; 11 - -1-50/35; 3 - 15; 8 - - ; 4 - 20; 9 - -1-12 ; 13 - -50 ; 12 - -1-12 ;

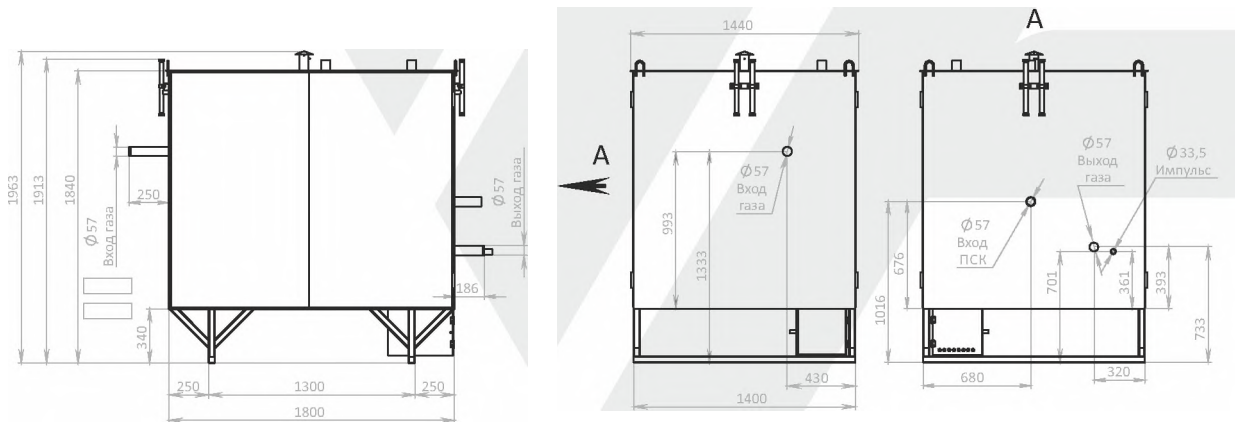

-12 ()-2 1- -

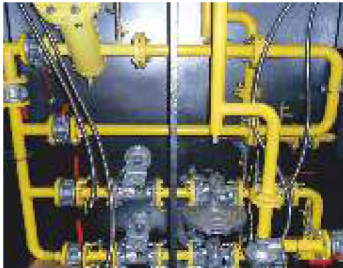

^_

-12 ()-2 1- -

1-25 1-25
1-50 1-50

1,2

5542-87

-40...+60

1-60

30-600

±10

-50

-50

1,7...90

70...900

0,5...30

9...300

-50

2-125

20-1000

15

^_

3'

0,05 0,2 0,3 0,4 0,5 0,6 0,7 0,8 0,9 1,0 1 1,2

1-25 /25

1-25 /25

1-50 /25

1-50 /25

1-50 /35

1-50 /35

-	450	675	900	1125	1350	1575	1800	2025	2250	2475	2700	2925
-	900	1360	1816	227	2714	3178	3632	4086	4541	4995	5736	6500

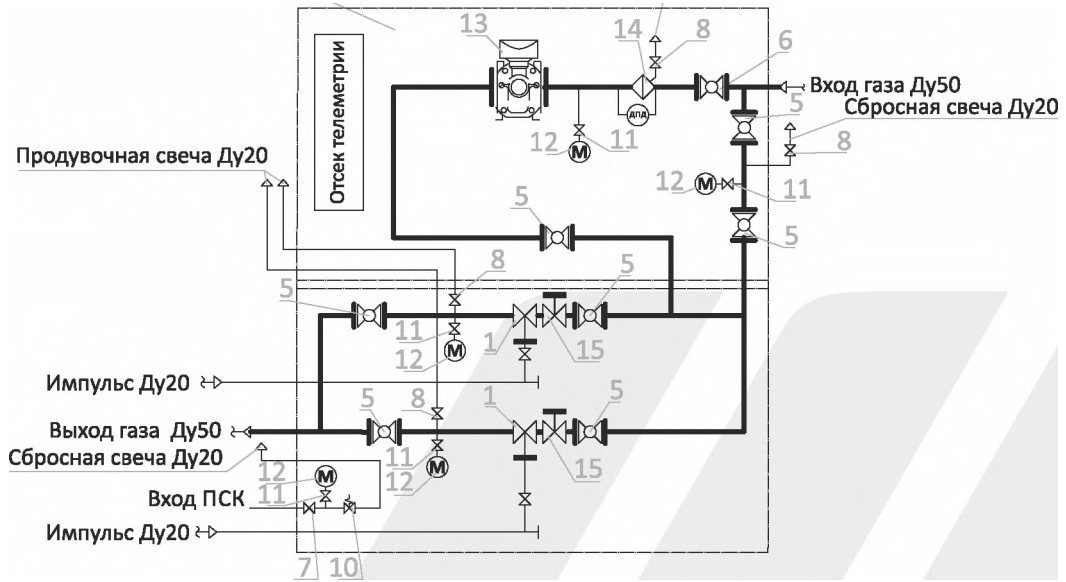

- 1 - ; 15; 8 - ; 20; 10 - ; 50; 6 - ; 50; 7 -
 12 - ; 13 - ; ; 11 - ; 14 - ; 15 -

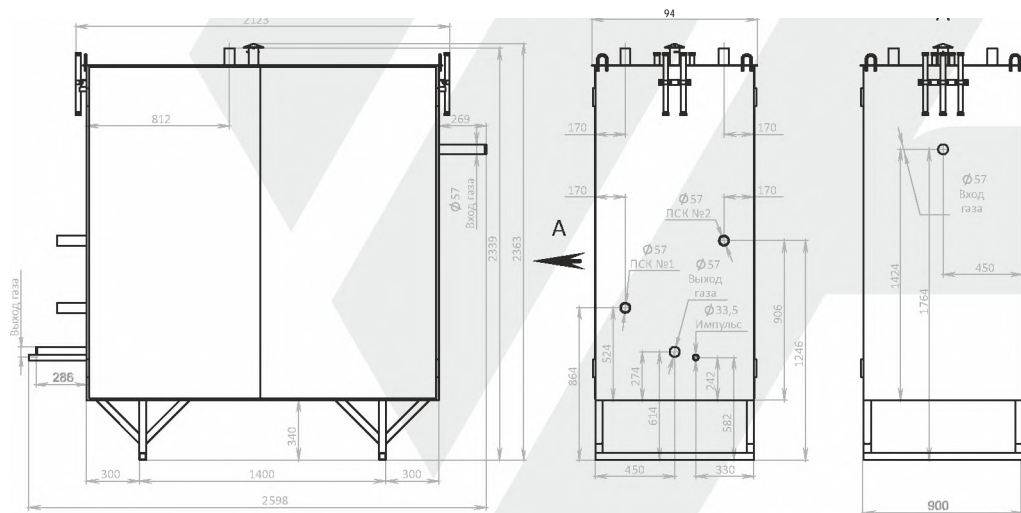

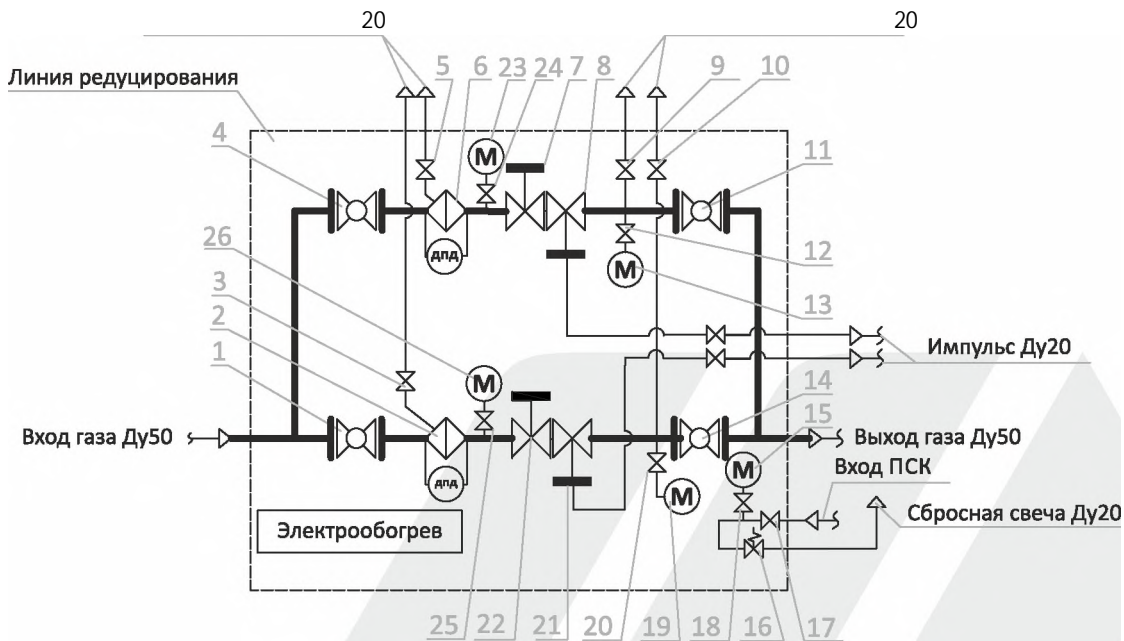

1,4,11,14,17 - 50; 2,6 - -50 ; 3,5,9,10 - ; 7,22 - 20; 7,22 -
 () ; 16 - - ; 2,3,2,6 - ; 15; 13,15,19 -

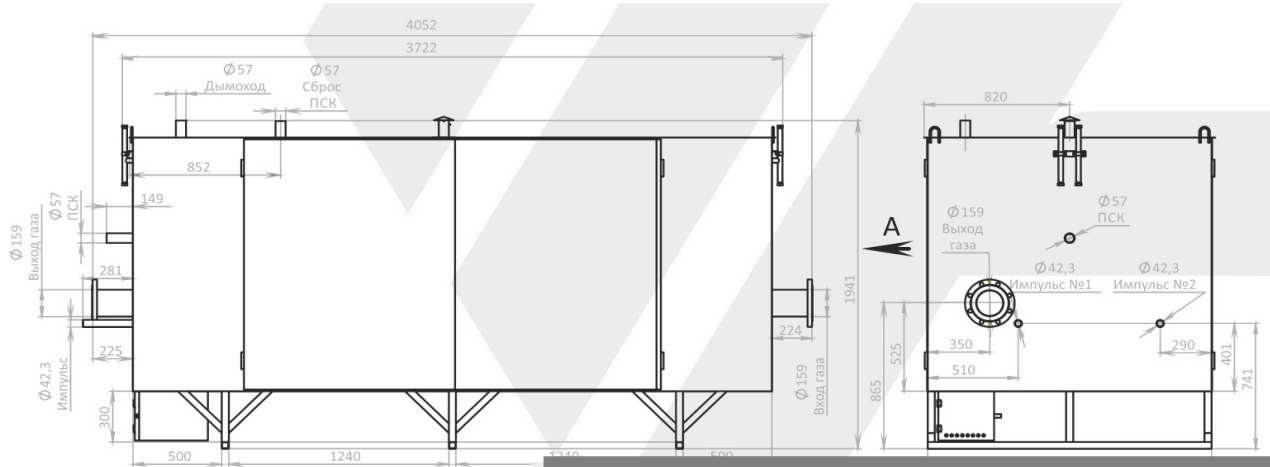

-13 ()-2 1- -



^_

-13)-2 1- -
 -50 -50
 1,2
 5542-87
 -40...+60
 1,5-60 | 60-600
 ±10
 (1,25...1,5)
 (0,15...0,5)
 -50
 2-125 20-1000

15

3'

	0,05	0,1	0,2	0,3	0,4	0,5	0,6	0,7	0,8	0,9	1,0	1	1,2
-50	0 30	250											
-50	0 30	-	450	650	850	1100	1300	1500	1700	1950	2150	2350	2600 2800
-50	0 35	330											
-50	0 35	-	600	950	1250	1550	1850	2150	2500	2800	3100	3400	3700 4050
-50	0 40	470											
-50	0 40	-	850	1250	1700	2100	2500	2950	3350	3800	4200	4600	5050 5450
-50	0 45	600											
-50	0 45	-	1100	1650	2200	2500	3280	3800	4350	4900	5450	6000	6550 7100

-13 ()-2 1- -



^_

-13 ()-2 1- -

-50

-50

1,2

5542-87

-40...+60

1,5-60

60-600

±10

(1,25...1,5)

(0,15...0,5)

-50

2-125

20-1000

15

3'

	0,05	0,1	0,2	0,3	0,4	0,5	0,6	0,7	0,8	0,9	1,0	1	1,2	
-50	0 30	250												
-50	0 30	-	450	650	850	1100	1300	1500	1700	1950	2150	2350	2600	2800
-50	0 35	330												
-50	0 35	-	600	950	1250	1550	1850	2150	2500	2800	3100	3400	3700	4050
-50	0 40	470												
-50	0 40	-	850	1250	1700	2100	2500	2950	3350	3800	4200	4600	5050	5450
-50	0 45	600												
-50	0 45	-	1100	1650	2200	2500	3280	3800	4350	4900	5450	6000	6550	7100

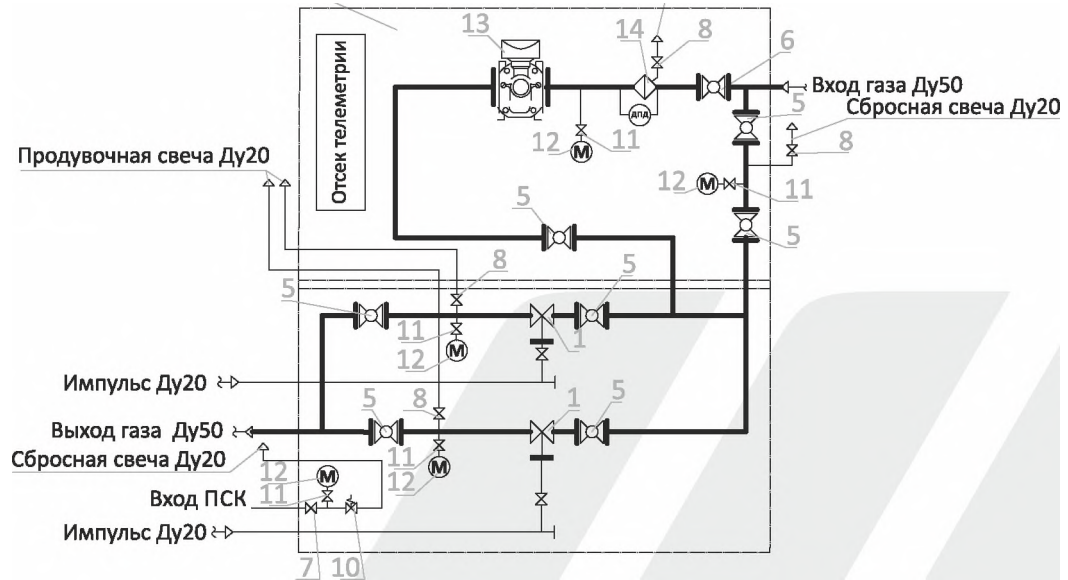

1 -

-50 /30; 5 -

20; 10 -

50; 6 -

- ; 11 -

50; 7 -

12 -

15; 8 -
; 13 -

; 14 -

50

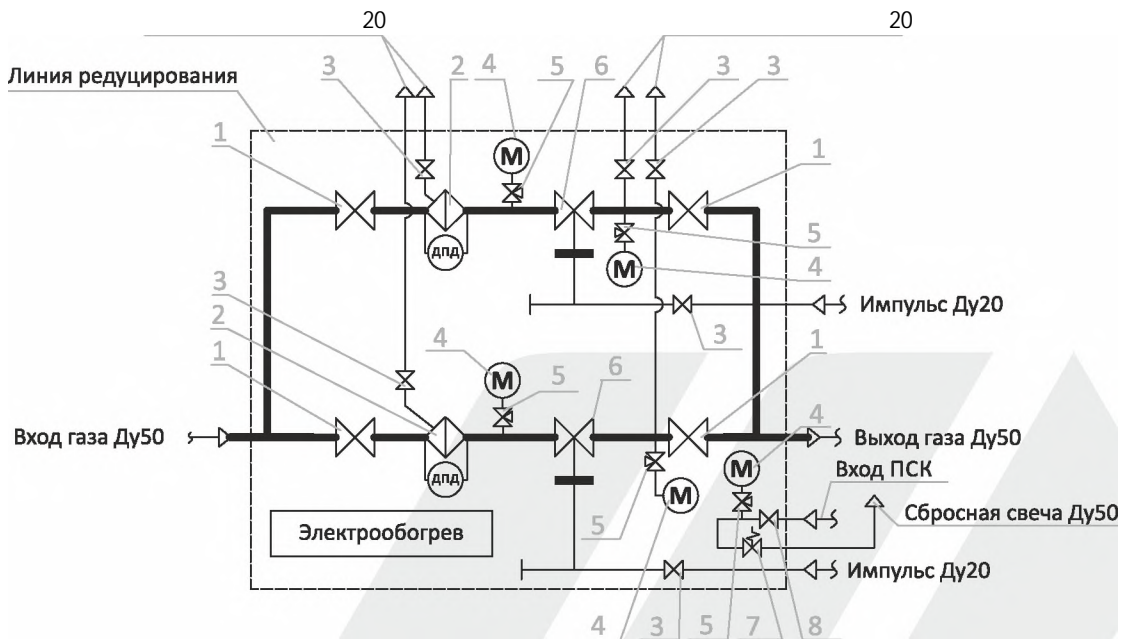

1- 50; 2- -50 ; 3- 20; 4- 50 () ;
 5- 15; -50 /30; 7- ; 8-

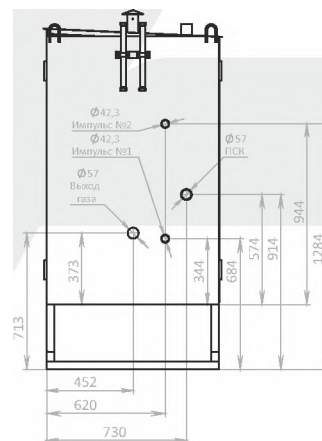
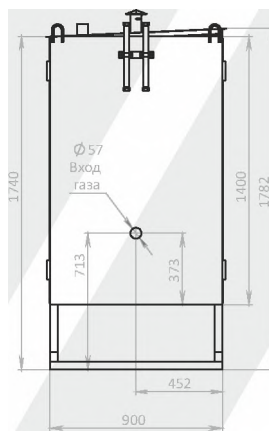
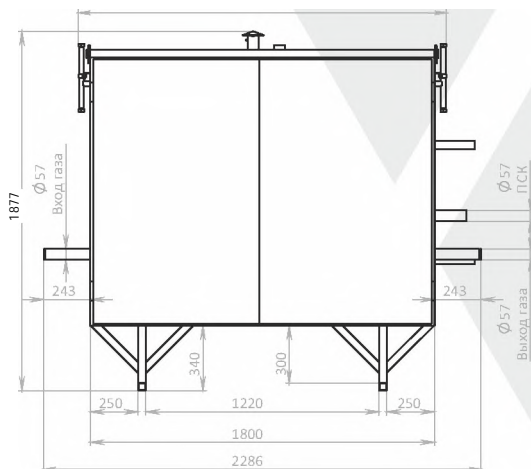

ГРУ-14Н(В)-2У1-ЭК*



-14 ()-2 1-
 -1-100 -1-100
 1,2
 5542-87
 -40...+60
 1-60 30-600
 ±10
 1,4...75 30...750
30
 -50
 2-125 20-1000
 15

	0,05	0,2	0,3	0,4	0,5	0,6	0,7	0,8	0,9	1,0	1	1,2	
1-100 /70	-	2816	4224	5632	7040	8442	9812	11149	12672	14080	14488	16896	18350
1-100 /70	-	2816	4224	5632	7040	8442	9812	11149	12672	14080	14488	16896	18350

*

-14 ()- (,)

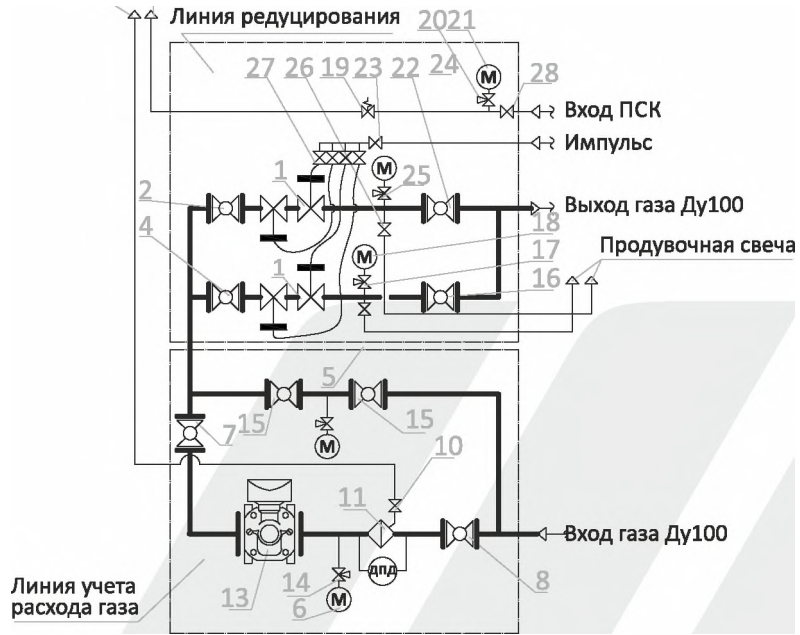

1 - ; 28 - ; 14,17,20,25 - ; 28 - ; 15: 19 - ; 23 - ; 25 - ; 5,10,26 - ; 20: 6,18,21,24 - ; 11 - ; 13 - ; -0,5-650/1, ;

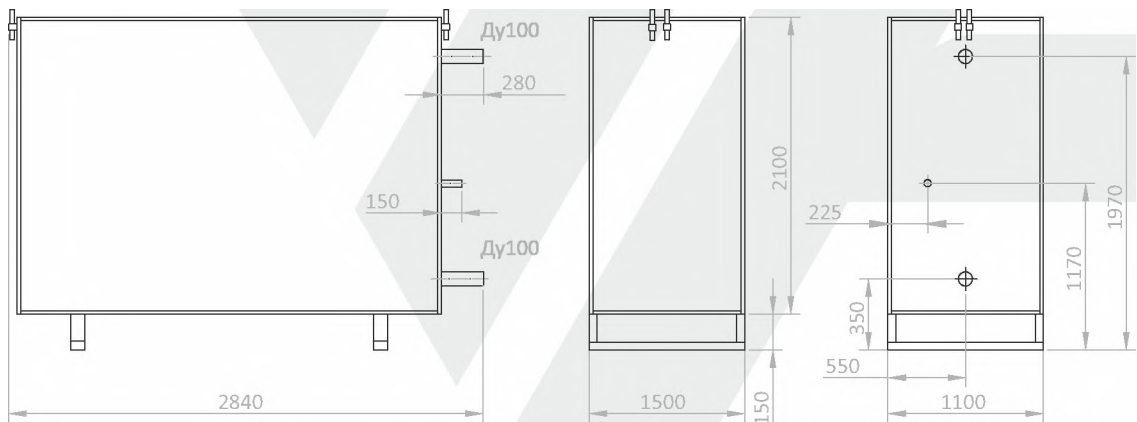

ГРПШ-15Н(В)-2У1-ОГ*



-15 ()-2 1-
 -80 1,2 -80
 5542-87
 -40...+60
 1,5-60 60-600
 ±10
 (1,25...1,5)
 (0,15...0,5) 0,9
 -50
 2-125 20-1000
 15

3'

	0,05	0,1	0,2	0,3	0,4	0,5	0,6	0,7	0,8	0,9	1,0	1	1,2	
-80	0 65	250	2250	3400	4500	5600	6750	7850	9000	10100	11200	12350	13450	14600
-80	0 65	-												

*

:

;

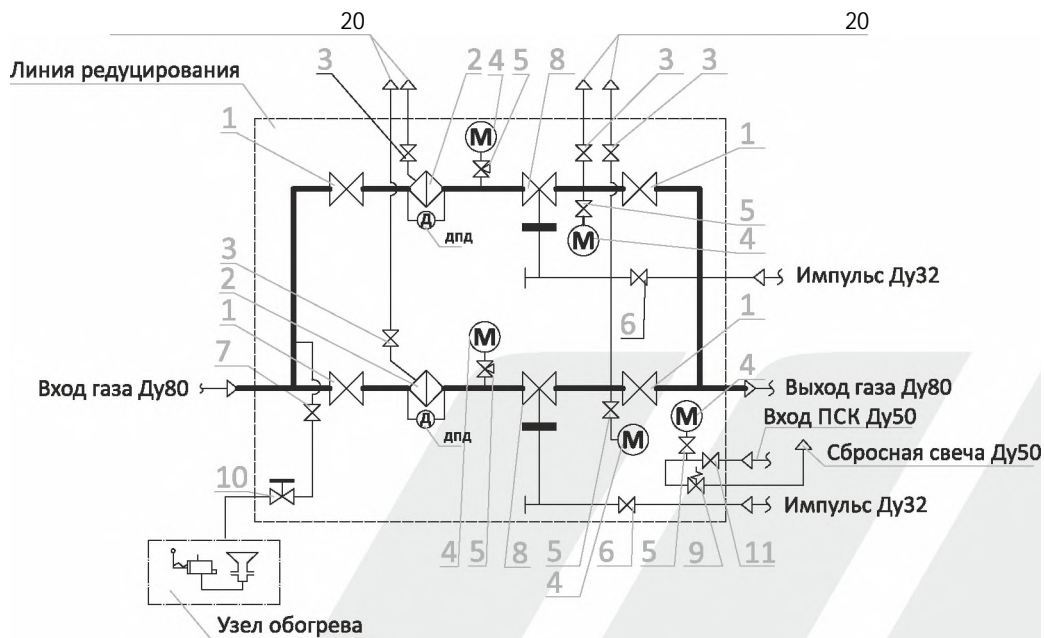

1 - ; 3 - ; 20; 4 - ;
 5 - ; 10 - ; 15; - 80; 2 - -80 ; 32; 7 - 50 ; 15; 8 - -80; 9 - ;

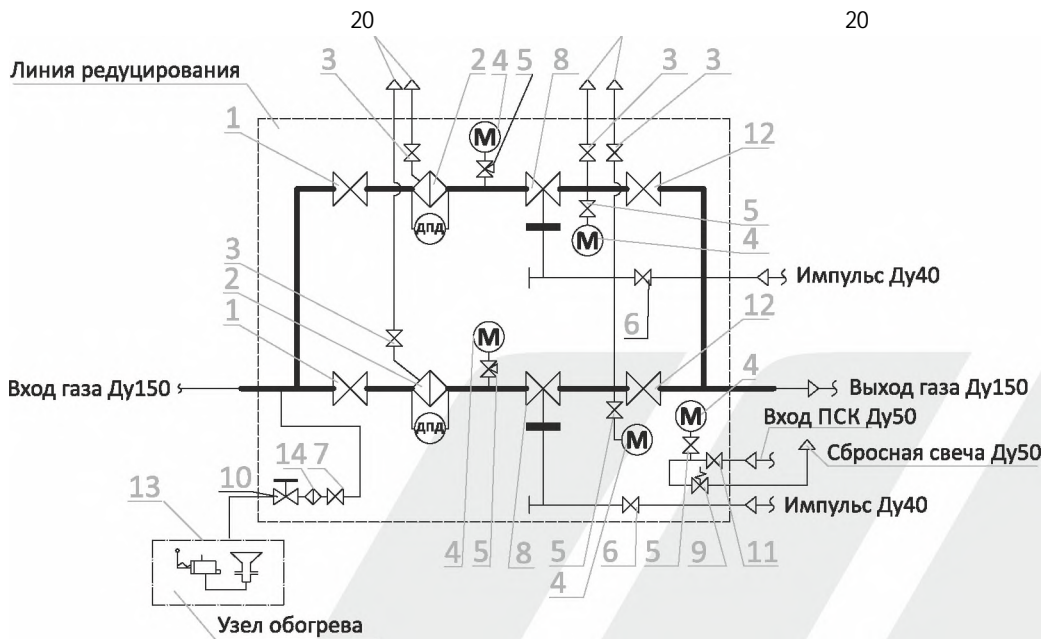

1 - ; 3 - ; 20; 4 - ;
 5 - ; 10 - ; 15; 6 - ; 150; 2 - ; -150/300 ; 3 - ;
 ; 10 - ; -10; 11 - ; 40; 7 - ; 50; 12 - ; 15; 8 - ; -150 ; 9 - ;
 5 ; 150; 13 - ; 14 - ;

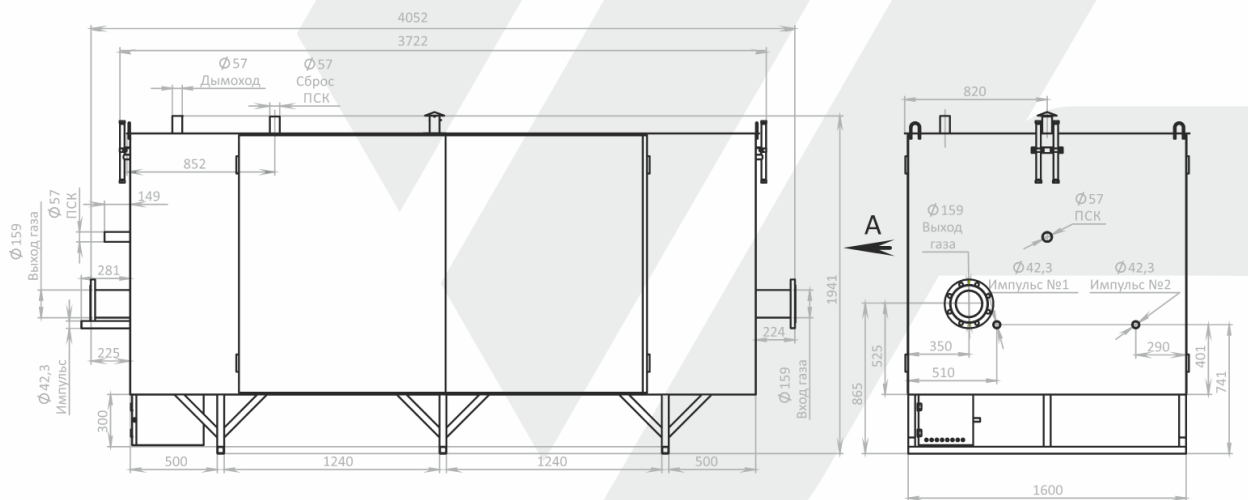

Газорегуляторные пункты блочные ГРПБ



1.2

5542

(« »)

(« »),

