

# CGR-FX

## Rotary Gas Meter for fiscal measurements



Rotary gas meters are positive displacement meters, designed to measure quantity of gas, for custody transfer or technical measurement applications.

The CGR-FX Meters are applied in measurement systems where high accuracy is required:

- transportation and distribution of natural gas
- primary and secondary measurements
- control metering of natural gas and non aggressive technical gases in industry
- flow measurement for technical purposes

Being a very precise instruments, resistant to disturbances and having a wide measurement range, the CGR-FX Meters satisfy all technical demands of customers.

The CGR-FX Meter consists of the following main assemblies:

- Pressure resistant housing (1)
- Index head (2)
- Magnetic coupling (3)
- Measuring assembly (4)

All parts subject to servicing or maintenance, like mechanical counter, LF (HF) sockets, oil filler and drain plugs, oil level sight-glass, are located on the front side of the meter. Thanks to this, it is not necessary to access the back

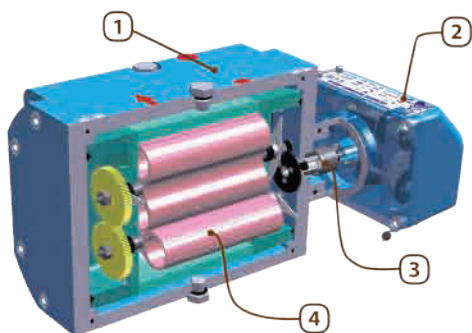

side of the meter and then it could be located very close to a wall or other construction element what reduces the installation deep.

The gas flow through the rotary gas meter measurement chamber makes the two "8"-shaped rotors to turn. The volume of gas closed between the measuring chamber walls and rotors is transported four times in one full cycle from the meter inlet to the outlet. The timing gears set the rotors at the angle of 90° one to the other. The gear train, and the incorporated gas tight and hermetic magnetic coupling, transfers the rotor rotation to the index unit, which is separated in that way from the pressure tight housing. The actual volume of gas is indicated on the mechanical counter. The measurement cartridge, as a separate unit, is fixed in the pressure resistant housing by means of elastomere gaskets. Thanks to this, the possible stresses, e.g. arising from improperly aligned piping, have no influence on measurement results of the CGR-FX Meter. Moreover, the measuring cartridge elements are made of materials with carefully selected values of thermal expansion coefficients. This minimizes temperature stresses that could cause the rotor seizures. All above factors, together with the highest precision machining of parts allow to reduce small but necessary clearances between the moving rotors and the measurement chamber walls, what reduces gas leakages to minimum and results in very high accuracy and wide measuring ranges of our CGR-FX Meters.

- ✓ pressure rating:  
PN16, ANSI150  
other on request
- ✓ HTR version available
- ✓ nominal diameter:  
DN40 up to DN100
- ✓ meter external housing:  
aluminium or cast iron
- ✓ flow:  
0.2 to 650 m<sup>3</sup>/h
- ✓ rangeability:  
up to 1:250  
(depending on the meter)
- ✓ temperature range:  
gas temperature -20°C to +60°C  
ambient temperature -25°C to +70°C
- ✓ operating position:  
horizontal or vertical
- ✓ accuracy class 1,0  
according to EN12480 standard:  
 $Q_t \div Q_{max} < \pm 1\%$   
 $Q_{min} \div Q_t < \pm 2\%$
- ✓ approvals:
  - MID
  - PED
  - ATEX
- ✓ traceability to PTB standards

## Dimensions and weights

Overall dimensions and weights of CGR-FX meters

### Serie "171"

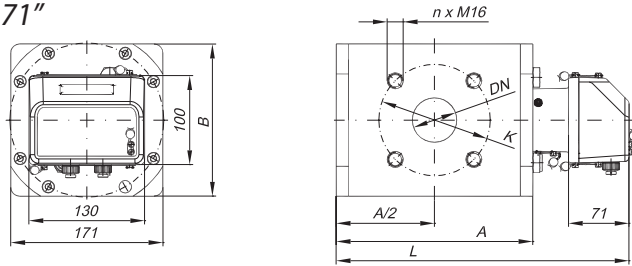

### Serie "241"

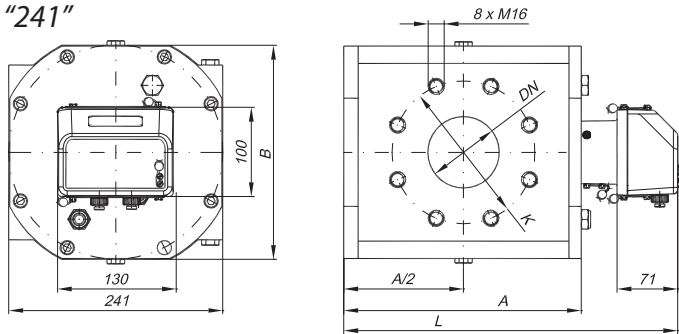

Table 1: Dimensions and weights of rotary gas meters (standard version).

	DN				n	A mm	B mm	L mm	Weight kg	Cyclic volume dm <sup>3</sup>
	40	50	80	100						
<b>ALUMINIUM CASING</b>										
G10	+	+			4	165	171	277	10	0,23
G16	+	+			4	165	171	277	10	0,23
G25	+	+			4	184	171	296	12	0,31
G40	+	+			4	225	171	337	14	0,50
G65		+			4	295	171	407	19	0,81
G100		+			4	391	171	503	24	1,24
G100			+		8	391	171	503	24	1,24
G100			+	+	8	249	241	356	25	1,29
G160			+	+	8	314	241	421	31	2,00
G250			+	+	8	439	241	546	42	3,34
G400				+	8	439	241	546	42	3,34
<b>CAST IRON CASING</b>										
G10	+	+			4	246	181	358	33	0,50
G16	+	+			4	246	181	358	33	0,50
G25	+	+			4	246	181	358	33	0,50
G40	+	+			4	246	181	358	33	0,50
G65	+	+			4	316	181	428	38	0,81
G100		+			4	412	181	524	45	1,24
G100			+		8	412	181	524	45	1,24
G100			+	+	8	327	253	439	64	2,00
G160			+	+	8	327	253	449	64	2,00
G250			+	+	8	452	253	564	78	3,34
G400				+	8	452	253	564	78	3,34

All information included in the table refer to Basic version of the meters. It is possible to manufacture compact version (smaller sizes, higher possible rangeability, higher noise level) and low speed version (bigger sizes, smaller possible rangeability, lower noise level).

Contact your local representative or the producer to get more information about the products.

## Metrology

The meters are manufactured in accordance with EC regulations and OIML recommendations. The maximum permissible error, according to EN12480 is  $\pm 2\%$  in the range  $Q_{\min} \div Q_t$  and  $\pm 1\%$  in the range  $Q_t \div Q_{\max}$ . Maximum rangeability may be up to 1:250 for larger meters (refer to Table 2).

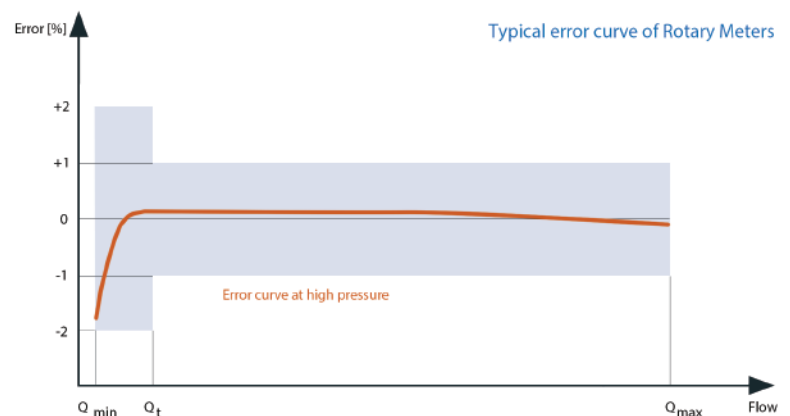

## Outputs

- ✓ As an option the meters can be provided with maximum 6 pulse transmitters
- ✓ 2 off LFK – low frequency reed contact pulse sensor
- ✓ 2 off LFI – low frequency inductive pulse sensor (NAMUR)
- ✓ 2 off HF – inductive pulse sensors in the index head (NAMUR)
- ✓ AFK – anti-fraud reed contact (available as an option)
- ✓ Amphenol TUCHEL connectors
- ✓ Index housing made of aluminium what perfectly protects index head against accidental damages
- ✓ Index housing may be provided with two separate sockets
- ✓ 2 pressure measurement taps as standard
- ✓ 2 temperature measurement taps (thermowells on request)



Index head with encoder (option)

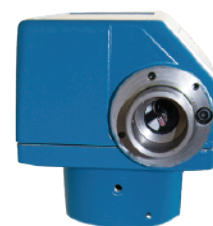

Index head with mechanical output (option)

## Pressure loss

Pressure drop during the gas flow through the meter according to EN12480 is determined for air at atmospheric conditions.

To calculate pressure drop for other gases at higher pressures, the following formula may be used:

$$\Delta p_{rz} = \rho_w \cdot \left( \frac{p_a + p}{p_a} \right) \cdot W_{pd} \cdot \Delta p$$

Definitions:

$\Delta p_{rz}$  = pressure loss at p [Pa]

$W_{pd}$  = coefficient from the diagram below

$\Delta p$  = pressure loss at  $Q_{max}$  from Table 2 [Pa]

$\rho_w$  = specific density of gas related to air

$p_a$  = base pressure (1.01325 bar)

$p$  = gauge pressure upstream

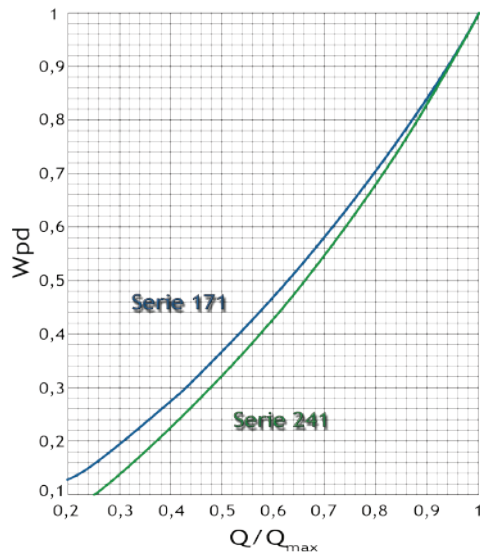

Table 2: Specification of the rotary gas meters in aluminium and cast iron housings

DN	G	Max flow $Q_{max}$ [m <sup>3</sup> /h]	Minimum flow $Q_{min}$ [m <sup>3</sup> /h]						LF pulse rate [pulse/m <sup>3</sup> ]	HF pulse rate [pulse/m <sup>3</sup> ]	V cyclic volume [dm <sup>3</sup> ]	Pressure loss at $Q_{max}$ [Pa]	Series
			1:50	1:65	1:100	1:160	1:200	1:250					
<b>ALUMINIUM CASINGS</b>													
40/50	10	16	0,30	0,25	0,16	-	-	-	10	15459	0,23	110/85	171
	16	25	0,50	0,40	0,25	0,16	-	-	10	15459	0,23	185/140	171
	25	40	0,80	0,65	0,40	0,25	0,20	0,16	10	11470	0,31	240/180	171
	40	65	1,30	1,00	0,65	0,40	0,30	0,25	10	7111	0,50	280/210	171
50/80	65	100	2,00	1,60	1,00	0,65	0,50	0,40	10	4390	0,81	325/290	171
	100	160	3,20	2,50	1,60	1,00	0,80	0,65	1	2867	1,24	505/395	171
80/100	100	160	3,20	2,50	1,60	1,00	0,80	0,65	1	1654	1,29	220/160	241
	160	250	5,00	4,00	2,50	1,60	1,30	1,00	1	1067	2,00	370/280	241
80/100	250	400	8,00	6,50	4,00	2,50	2,00	1,60	1	639	3,34	510	241
100	400	650	13,00	10,00	6,50	4,00	3,20	2,50	1	639	3,34	1380	241
<b>CAST IRON CASINGS</b>													
40/50	10	16	0,30	0,25	-	-	-	-	10	7111	0,50	33/17	171
	16	25	0,50	0,40	0,25	-	-	-	10	7111	0,50	45/35	171
	25	40	0,80	0,65	0,40	0,25	-	-	10	7111	0,50	110/80	171
	40	65	1,30	1,00	0,65	0,40	0,30	0,25	10	7111	0,50	280/210	171
50/80	65	100	2,00	1,60	1,00	0,65	0,50	0,40	10	4390	0,81	325/290	171
	100	160	3,20	2,50	1,60	1,00	0,80	0,65	1	2867	1,24	505/395	171
80/100	100	160	3,20	2,50	1,60	1,00	-	-	1	1067	2,00	180/135	241
	160	250	5,00	4,00	2,50	1,60	1,30	1,00	1	1067	2,00	370/280	241
80/100	250	400	8,00	6,50	4,00	2,50	2,00	1,60	1	639	3,34	510	241
100	400	650	13,00	10,00	6,50	4,00	3,20	2,50	1	639	3,34	1380	241

NOTE: G40 and G65 meters available as DN65 on request.

All information included in the table refer to Basic version of the meters. It is possible to manufacture compact version (smaller sizes, higher possible rangeability, higher noise level) and low speed version (bigger sizes, smaller possible rangeability, lower noise level).

Contact your local representative or the producer to get more information about the products.

## Accessories

✓ Thermowells



✓ 3-way valve

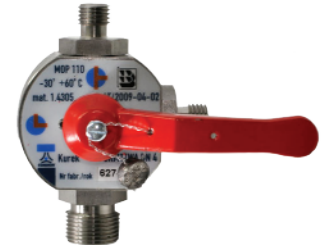

## Installation and operation recommendations

- Meters should be shipped in their original package to the place of installation.
- Meters have to be handled with care and protected against falls, direct influence of rain, snow or high humidity.
- The measured gas should be clean, dry and free from solid impurities.
- It is recommended that the upstream pipe installation is to be equipped with a filter (10 micron).
- Prior to putting into operation in new installations, it is recommended to install a temporary top hat filter.
- Prior to installation the upstream and downstream pipe flanges should be aligned properly.
- Flange gaskets are to be installed so as not to disturb the gas flow.
- The gas flow should be in accordance with the arrow placed on the meter body.
- The piping should be executed so as to avoid unnecessary stresses acting on the meter.
- When used outdoors the meter should be protected against direct weather influence.
- When starting the gas flow through the installation, the valves should be opened slowly to ensure a gradual increase of pressure.

**ATTENTION!** If valves are opened abruptly or pressure increase takes place in a short time it may happen that the measurement cartridge get damaged.

**INCREASE PRESSURE GRADUALLY - NO MORE THAN 350 mbar/s!**

**ALWAYS REMEMBER TO START UP THE METERS IN A PROPER WAY!**